



PS-450XL

45:1



MAX. WORKING
PRESSURE: 315 bar

MAX. AIR INLET
PRESSURE: 7 bar



WARNING

This equipment is designed to be used only for pumping non-corrosive and non-abrasive lubricants and greases. Any other use of the machine may result in unsafe operation.

I.MANUAL

**DECLARACION DE CONFORMIDAD “CE”
“EC” DECLARATION OF CONFORMITY**

MODELO / MODEL PS-450XL 45:1

Este producto cumple con la siguiente directiva de la Comunidad Europea.

This Product complies with the following European Community Directive.

Directiva 2014/34/EU Atex sobre máquinas. (Ex II 2G c T6 X)
Machinery Directive 2014/34/EU Atex Directive. (Ex II 2G c T6 X)

APROBADO POR /
APPROVED BY

AITOR ORTIZ

FECHA / DATE

MBP, S.L. figura inscrita en el Registro Industrial del País Vasco con el N° 01/8030 y cumple los requisitos para el desarrollo de su actividad comercial.

MBP, S.L. is registered in the Industrial Register of the Basque Country with the N° 01/8030.



INDEX

SYMBOLS	2
INSTALLATION	4
OPERATION	5
START-UP	6
TROUBLESHOOTING GUIDE	7
PARTS LIST	8
AIR MOTOR PARTS	10
MAINTENANCE	12
DISPLACEMENT PUMP PARTS.....	13
PNEUMATIC ELEVATOR PARTS	14
PNEUMATIC CONNECTIONS	16
TECHNICAL DATA	18



WARNING

THIS SYMBOL ALERTS YOU ABOUT THE POSSIBILITY OF SERIOUS INJURIES OR DEATH IF INSTRUCTIONS ARE NOT FOLLOWED.



CAUTION

THIS SYMBOL WARNS OF THE POSSIBILITY OF DAMAGE OR DESTRUCTION OF EQUIPMENT IF YOU DO NOT FOLLOW INSTRUCTIONS.



WARNING



INSTRUCCIONES

DANGER DUE TO MISUSE OF THE MACHINE

- Incorrect use can cause equipment to malfunction or even shatter and cause accidents.
- Consult the instruction's handbook before using the equipment.
- Use the equipment for its intended purpose.
- Check periodically the equipment and replace the damaged parts.
- Do not exceed the maximum pressure in the equipment.
- No strangulate neither hoses nor nipple.
- No move or lift the equipment with pressure.
- Bear in mind all the local procedure of safety.

TOXIC FLUID OR FUMES HAZARD



- Toxic fluids or fumes can cause serious injury if splashed in the eyes or on skin, inhaled, or swallowed.
- Know the specific hazards of the fluids you are using.



TOXIC FLUID OR FUMES HAZARD

- Store hazardous fluid in approved containers.
- Use always gloves, mask, glasses and clothes to be protected from the possible hurts.



FIRE AND EXPLOSION HAZARD

- Poor ventilation, poor grounding or a spark can create a dangerous situation, causing fires or explosions.



- Ground equipment and conductive objects in work area. See grounding instructions.
- If there is static sparking or you feel a shock, stop operation and do not use the equipment again until you identify and correct the cause.
- Use the equipment in well ventilated area.
- Keep the work area free of debris, including solvent, rags and gasoline.
- Do not smoke in the work area
- Keep a fire extinguisher in the work area.



MOVING PARTS HAZARD

- Moving parts can pinch or amputate fingers and other body parts.
- Keep clear of moving parts
- Do not operate equipment without protective guards or covers removed.
- Before checking, moving, or servicing equipment, follow the pressure relief procedure.

GROUND CONNECTION

It is essential to ground the equipment to maintain safety in the installation. This reduces the risk of sparks caused by static electricity. Ensure that you obtain a true 'GROUND' and use electrically conductive hoses. The product container must comply with current regulations.

Grounding point

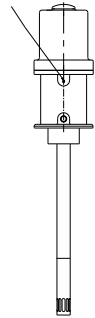

(fig.1)

Recommended air pipe route to reduce humidity in the pump unit.

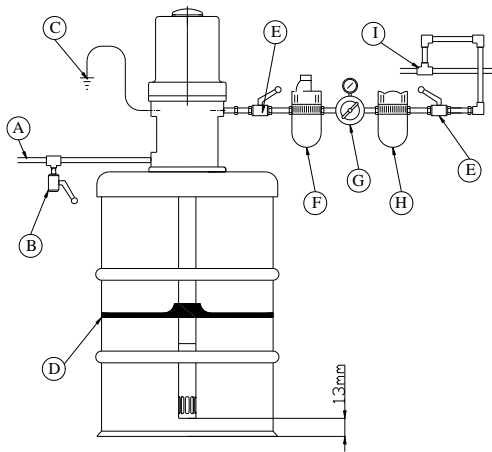

(fig.2)

DESCRIPCION

- A.- PRODUCT OUTLET PIPE
- B.- PURGE VALVE (PRODUCT)
- C.- GROUND CONNECTION
- D.- FOLLOWER PLATE
- E.- THREE-WAY VALVE (AIR PURGE)
- F.- AIR LUBRICATOR
- G.- AIR REGULATOR WITH PRESSURE GAUGE
- H.- AIR PURIFIER
- I.- AIR INSTALLATION



WARNING

Install the pump securely so that it cannot move during operation.

1.- During installation, ensure that the operator has easy access to the air regulators for the pump and lift. Check that there is enough space above the pump and lift when they are in their highest position.

2.- Use wedges to level the base of the lift.



WARNING

Your system requires three accessories:

- 1.- A three-way air inlet valve.
- 2.- A three-way valve for product purging.
- 3.- A grounding cable is required.

By incorporating these three elements, you can significantly reduce the risk of accidents.

The valves are designed to decompress the equipment.



WARNING



INJECTION DANGER

The equipment is pressurized until the pressure inside is manually released. To reduce the risk of accidents and serious damage caused by liquid escaping from the dispensing gun, you must depressurize the equipment whenever:

- A- Finish dispensing the product.
- B- When I change the drum.
- C- When servicing any part of the installation or equipment.
- D- Review, inspect, or install new items.



WARNING



MOVING PARTS HAZARD.

The working pressure may not be the same for all components of the installation, so to reduce the risk of accidents, you should find out the recommended pressure for each element.

Do not exceed the working pressure of the component that supports the lowest pressure.

The pump creates a pressure 45 times greater than that of the air inlet. Knowing which components can withstand lower pressure, multiply the indicated inlet pressure by 60 to allow for a safety margin.

- 1- Close the pump air regulator until it reads "0" bar.
- 2- Close the air passage of the three-way air valve. This is near the pump. This will release pressure from the motor.
- 3- Place a metal part of the gun in physical contact with a grounded metal waste container and squeeze the trigger until no more product comes out.
- 4- Open the product's purge valve "B" (fig. 2).



START-UP

- 1- Keep regulators n°11 and n°12 at ‘‘0’’ pressure (see fig. 4).
- 2- Ensure that valve n°8 is closed.
- 3- The line air should be introduced at point n°10 of the air group.
- 4- Open air valve n°9 on the unit. Move valve n°6 upward and apply pressure to regulator n°11 until the pump begins to rise; it will stop automatically when it reaches the highest point. (CAUTION: do not release the air pressure).
- 5- Place the container on the platform and remove the lid.
- 6- Open valve n°9 (see fig.5) on the follower plate and turn key n°6 (see fig. 4) downwards to slowly lower the pump until the follower plate is positioned on the drum. Then adjust the stops to fit the drum.
- 7- Once the follower plate is pushing the product, adjust the pressure of the plate on the product using regulator n°11 (see fig. 4).
 - a) If the pressure is too high in regulator n°11, the product will leak out around the edges of the follower plate and through valve n°9.
 - b) The pump will not prime or will lose its prime during operation if there is too low a pressure in regulator n° 11.
- 8- Close valve n°9 (see fig.5) on the follower plate once all the air between it and the product has been released.
- 9- We apply pressure directly to regulator n° 12 on the pump, starting to absorb the grease from the drum. We will keep the gun open for a short time, until the grease comes out of the gun.

DRUM CHANGE

- 1- The pump will stop when the follower plate is in the lower position. Set the regulator to n°12 to ‘‘0’’ pressure.
- 2- Slowly open valve n°8 and turn key n°6 upward.
- 3- When this operation is performed, the pump with its follower plate will rise and the drum will remain on the platform.
- 4- Close valve n°8.



WARNING

Follow the pressure relief procedure before servicing or installing the equipment to reduce the risk of accidents.

Release the pressure from the equipment before servicing any part of the installation.



WARNING



**MOVING PARTS
HAZARD.**

Never operate the pump without the protective plates on the air motor.

These plates protect the fingers from cuts or amputations.

PROBLEM	CAUSE	SOLUTION
The follower plate does not go up or down.	The air valve is closed or the air line is blocked.	Open or clean.
	Insufficient pneumatic pressure.	Increase.
The follower plate moves up or down too quickly.	Pressure too high.	Reduce the pressure.
Air loss in pneumatic cylinders.	The guide is for loose pneumatic axles or worn joints.	Replace.
Product loss.	Pressure is too high.	Decrease.
	Worn or damaged joints	Replace.
The pump is pumping air, or it is not priming correctly.	Insufficient pressure.	Increase the pressure.
	There are worn or damaged gaskets.	Replace.
	The control valve is closed or blocked.	Open, clean, or replace.
The air valve does not keep the reservoir down or push the follower plate up.	Air valve closed.	Open.
	The air line is blocked.	Clean.
	Insufficient pneumatic pressure.	Increase.



(fig.3)

- 1.- AIR MOTOR (A.400.00)
- 2.- LOWER PUMP (450.200.00)
- 3.- PNEUMATIC ELEVATOR (451.100.00)
- 4.- AIR REGULATORS ASSEMBLY (451.400.00)
- 5.- GAUGE (CNB.001)
- 6.- VALVE (UP-DOWN) (CNC.026)
- 8.- VALVE (CNC.004)
- 9.- AIR VALVE (CNC.008)
- 10.- AIR INLET (CNA.073)
- 11.- PRESSURE REGULATOR FOLLOWER PLATE (CNB.052)
- 12.- AIR REGULATOR PUMPING (CNB.065)

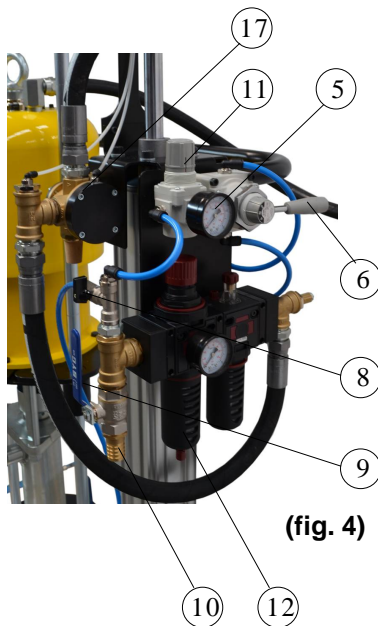

(fig. 4)

- 14.- LIGHT(CET.020)
- 15.- "T" (CNA.003)
- 17.- VALVE (CNC.030)
- 18.- NON RETURN VALVE (CNA.159)
- 19.- LIMIT SWITCH (CNA.029)

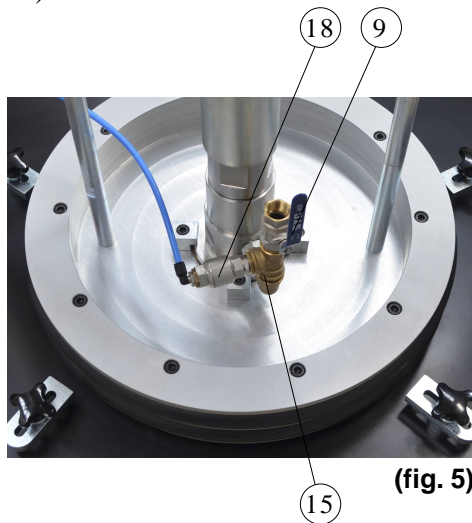

(fig. 5)

The working pressure should be between 2 and 5.5 bars.

N°	REF.	DESCRIPTION	Q
1	A.421.00	PISTON	1
2	CJT.018	O-RING	1
3	A.422.00	SHAFT	1
4	A.420.01	CONNECTOR	1
5	CAB.008	PACKING	1
6	A.430.03	JOINT	2
7	A.400.03	JOINT	1
8	CJT.019	O-RING	1
9	CB2.009	SLEEVE	1
10	CB2.010	SLEEVE	1
11	A.430.01	MOTOR BODY	1
12	A.430.02	JOINT	1
13	CTT.008	SCREW	12
14	CTU.141	EYRE	1
15	CTT.006	SCREW	8
16	CTT.007	SPRING WASHER	8
17	A.440.00	AIR INLET COUPLING	1
18	A.400.01	HOUSING	1
19	CTT.005	SPRING WASHER	4
20	CTT.004	SCREW	4
21	A.410.08	SUPPORT	1
22	CPA.213	PIN	2
23	A.410.02	JOINT	2
24	A.410.03	SEAT	2
25	A.410.18	NUT	1

N°	REF.	DESCRIPTION	Q
26	CAR.053	SPRING WASHER	1
27	A.410.17	AIR VALVE HOUSING	1
28	A.410.19	HUB	1
29	A.411.00	NUT	1
30	CAR.012	JOINT	1
31	A.410.10	PLUNGER	2
32	A.410.12	SPRING DETENT	2
33	A.410.11	SPRING	2
34	A.410.13	SPRING RETAINER	2
35	A.410.09	ROLLER	2
36	CTT.002	SCREW	8
37	A.400.02	JOINT	1
38	CTT.001	SCREW	4
39	CTT.003	SPRING WASHER	4
40	A.410.04	JOINT	2
*41	A.410.05A	VALVE BODY	1
42	A.410.07	JOINT	2
43	A.410.06	VALVE SEAT	2
44	A.410.15	VALVE	2
45	CJT.001	O-RING	2
46	A.410.16	SPRING	2
47	A.410.01	CYLINDER	1
48	A.410.14	SPRING	1
49	CAR.021	WASHER	8
50	TIE.GR	GROUND	1
*51	A.410.05B	VALVE BODY	1

41* Valve body threaded

51* Valve body without thread

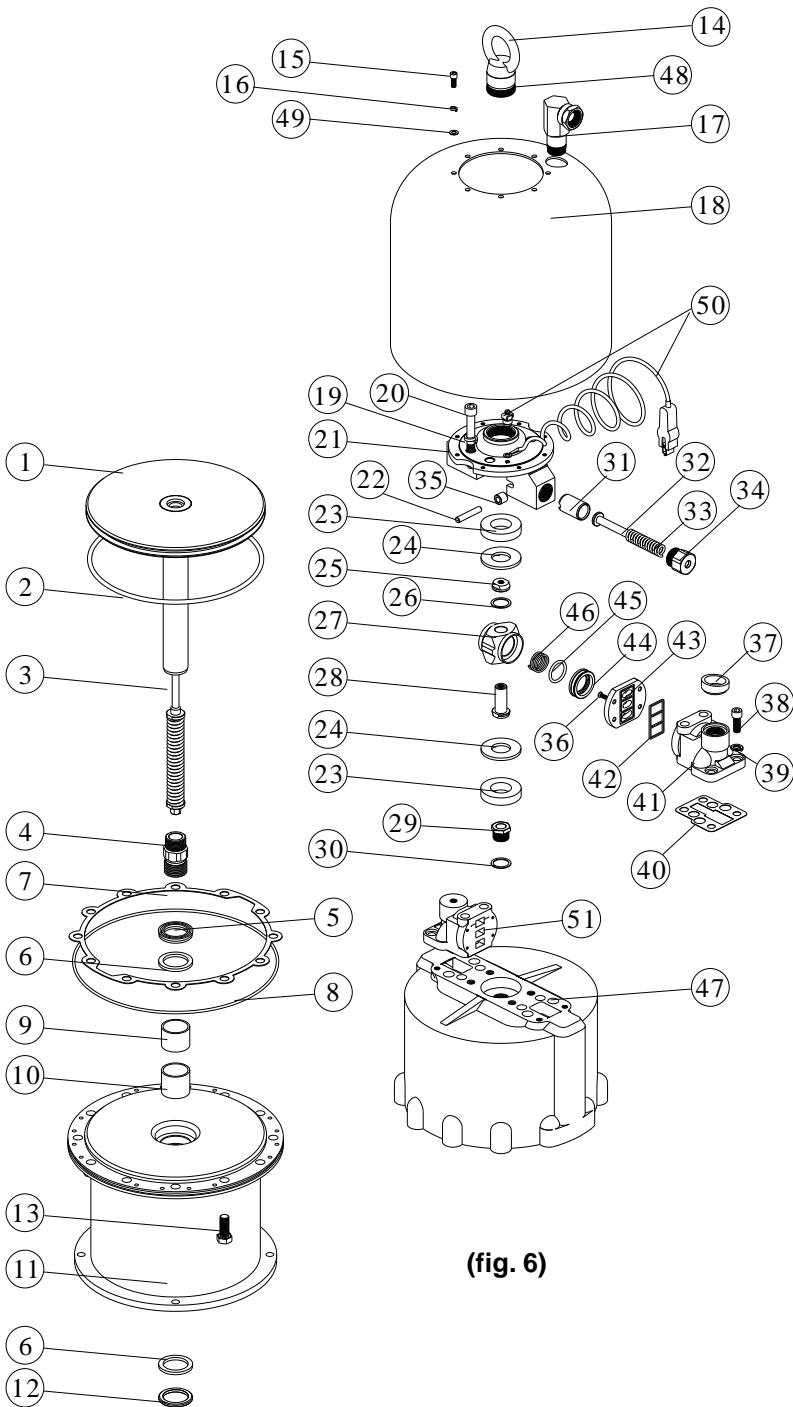

(fig. 6)

**WARNING**

Before starting any maintenance work on the equipment or installation, follow the **PRESSURE RELIEF PROCEDURE**.

- 1- Wash the pump, hose, and spray gun using a degreaser that is compatible with the product and with the wet parts of the equipment.
- 2- Depressurize the equipment following the **SAFETY RULES**.
- 3- It is essential that you disconnect the pump hose.
- 4- Loosen screws n°28 and stops n°27 (fig. 7). Loosen nut n°10 and screw n°11 (fig. 8) and the follower plate will be loose.
- 5- Unscrew nuts n°2 and n°9 (fig. 7) to release the displacement pump.
- 6- Unscrew cylinder n° 26 (fig.7).
- 7- Move the shaft downwards by striking piece n°3 (fig. 7) with a mallet, having first loosened gland n°4. (fig.7).
- 8- Unscrew cylinder n°20 from the pump body n°10 (fig.7).
- 9- Loosen handle n°21 (Fig. 7) to loosen the lock nut and parts n°24 and 22 will cause them to become loose.

- 10- Pull the shaft downwards and remove nut n°17, piston n°16 and packings if necessary. It is recommended not to touch the packings if they are not going to be replaced.
- 11- Replace all necessary parts. Whenever the displacement pump is loosened, it is recommended replace the seals at n°19 and 25.
- 12- Assemble the displacement pump in reverse order, taking into account the installation of the packing: polyethylene, teflon, polyethylene, etc.
- 13- When assembling piston n°16 on shaft n°12 (fig. 7), apply Loctite 542 and allow it to dry before assembly. Do the same when assembling nut n°17 (fig. 7).

**WARNING**

If you have any problems, please contact technical support. Do this before disassembling anything.

N°	REF.	DESCRIPTION	Q
1	C.410.01	CAP	2
2	C.410.02	NUT	1
3	C.510.05	TIE ROD	1
4	B.520.00	PACKING NUT	1
5	B.540.01	FEMALE GLAND	2
6 T	B.540.02T	PACKING	10
7	B.540.03	MALE GLAND	2
8	C.500.01	TIE	3
9	CTT.009	NUT	3
10	B.510.00	HOUSING	1
11	B.500.01	JOINT	1
12	B.550.00	ROD	1
13	B.500.02	SLEEVE	1
14	CBO.103	BALL	1
15	B.540.04	WASHER	1
16	450.210.00	PISTON	1
17	450.200.01	NUT	1
18	450.220.02	SEAL	1
19	B.560.02	O-RING	1
20	450.220.01	VALVE	1
21	450.230.00	TIE	1
22	450.240.00	SLEEVE	1
23	CJT.160	JOINT	1
24	450.220.03	END VALVE	1
25	450.220.04	JOINT	1
26	450.250.01	CYLINDER	1
27	450.250.03	END	4
28	CTB.042	SCREW	4
29	450.250.02	JOINT	1
30	450.261.02	PLATE	1
31	CJT.201	JOINT	2
32	450.261.03	PLATE	1
33	450.261.01	PLATE	1
34	CTB.051	SCREW	10
35	CPA.228	PIN	2

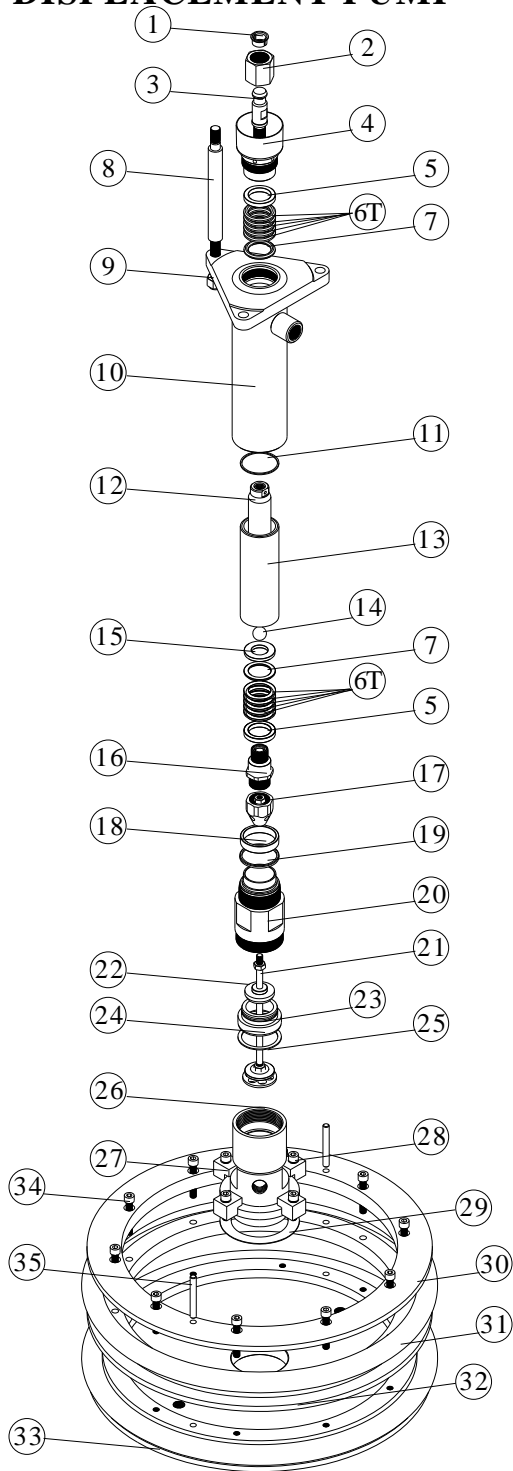

(fig. 7)

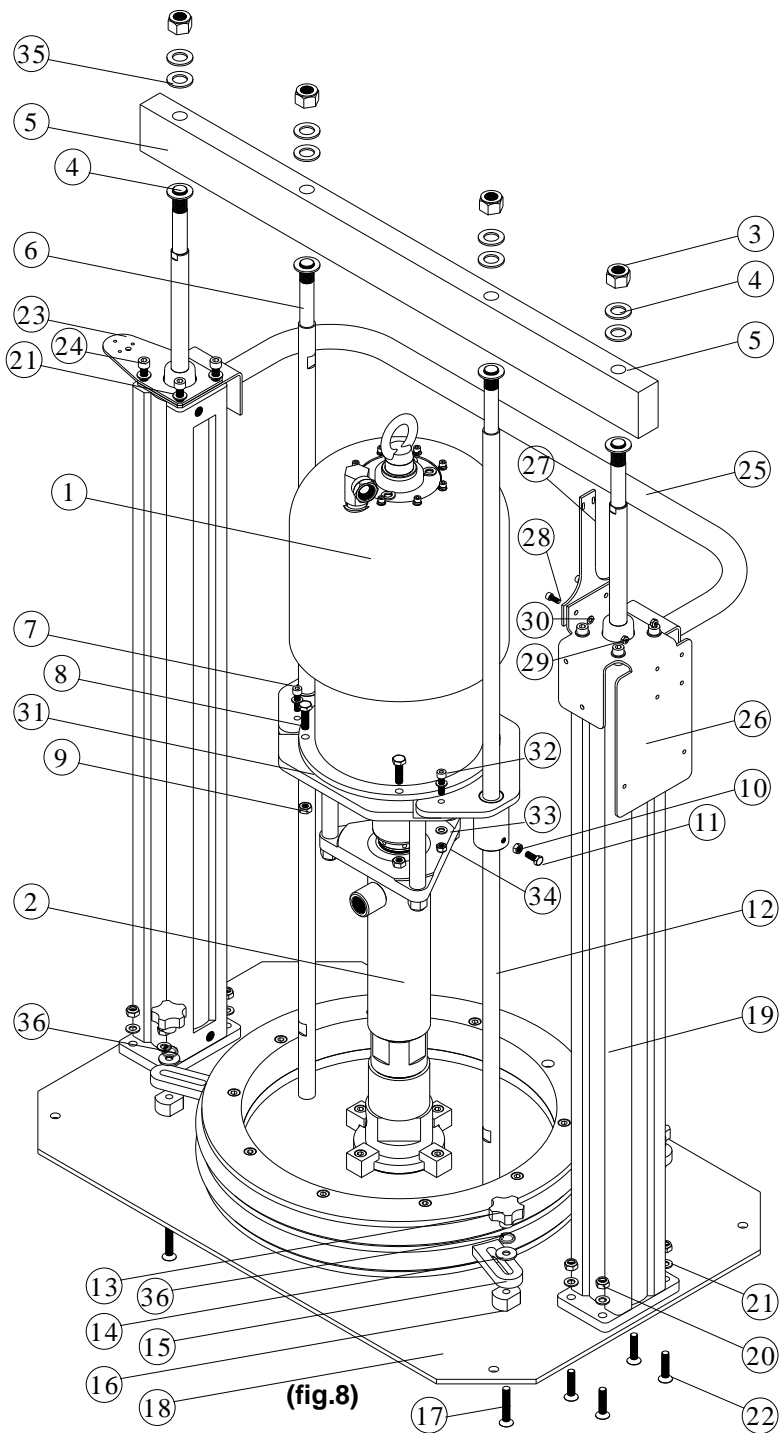

(fig.8)

N°	REF.	DESCRIPTION	Q
1	A.400.00	AIR MOTOR	1
2	450.200.00	DISPLACEMENT PUMP	1
3	CTU.010	NUT	4
4	CAR.029	WASHER	8
5	451.100.03	SUPPORT	1
6	451.100.01	TIE	2
7	450.100.02	SUPPORT AIR MOTOR	1
8	CTB.037	SCREW	4
9	CTU.003	NUT	4
10	CTU.001	NUT	2
11	CTA.001	SCREW	2
12	451.100.04	TIE	2
13	CAB.034	HANDLE	4
14	CAR.252	WASHER	4
15	450.100.07	STOP	4
16	450.100.08	BUSHING	4
17	CTB.103	SCREW	4
18	451.100.06	SUPPORT	1
19	CNS.003	PNEUMATIC CYLINDER	2
20	CTU.108	NUT	8
21	CAR.025	WASHER	16
22	CTB.104	SCREW	8
23	451.300.03	LIGHT SUPPORT	1
24	CTB.053	SCREW	8
25	451.310.00	TIE	1
26	451.300.02	GROUP SUPPORT	1
27	451.300.04	SUPPORT END STROKE	1
28	CTB.005	SCREW	2
29	CTU.105	NUT	2
30	CAR.021	WASHER	2
31	450.100.09	SUPPORT CLAMP	1
32	CTB.029	SCREW	2
33	CAR.006	WASHER	4
34	CTU.106	NUT	2
35	CAR.059	WASHER	4
36	CAR.256	WASHER	4



PARTS OF THE AIR ASSEMBLY AND CONNECTIONS

N°	REF.	DESCRIPTION	Q
1	CNB.065	LUBRI.+REGU.	1
3	CNB.001	GAUGE	2
4	CNA.008	NIPPLE	6
5	CNA.003	NIPPLE	3
6	CNA.044	NON RETURN VALVE	1
7	CNC.025	VALVE	1
8	CNA.154	NIPPLE	4
9	CTB.006	SCREW	2
10	CTU.103	NUT	2
11	CNA.073	NIPPLE	1
12	CNC.008	VALVE	2
13	CNA.009	NIPPLE	2
14	CNA.087	NIPPLE	1
15	CNA.067	NIPPLE	2
17	CNC.004	VALVE	1
18	CNA.052	NIPPLE	1
19	CNA.064	NIPPLE	9
20	450.410.00	HOSE	1
21	CNA.097	NIPPLE	1
22	CNC.030	VALVE	1
23	CAB.035	SILENCER	1
24	CTB.014	SCREW	2
25	CAR.021	WASHER	6
26	CTU.105	NUT	6

N°	REF.	DESCRIPTION	Q
27	CNA.029	LIMIT SWITCH	1
28	450.420.00	HOSE	1
29	CNB.052	REGULATOR	1
31	CNA.054	NIPPLE	2
32	CAB.037	SILENCER	1
33	CTB.016	SCREW	4
34	450.400.01	TUBE	4
35	CNA.096	NIPPLE	1
36	CNC.026	VALVE	1
37	CNA.126	NIPPLE	1
38	CNA.159	NON RETURN VALVE	1
39	CNA.005	NIPPLE	1
40	CNA.155	NIPPLE	1
41	CNA.056	NIPPLE	2
42	CTB.043	SCREW	2
43	CTU.102	NUT	5
44	CAR.002	WASHER	8
45	CTB.027	SCREW	3
46	CAR.008	WASHER	3
47	CET.020	LIGHT	1
48	CET.044	CONNECTOR	1
49	CNA.177	NIPPLE	2
50	CNA.135	NIPPLE	1
51	CNA.072	NIPPLE	1
52	CNA.099	NIPPLE	4

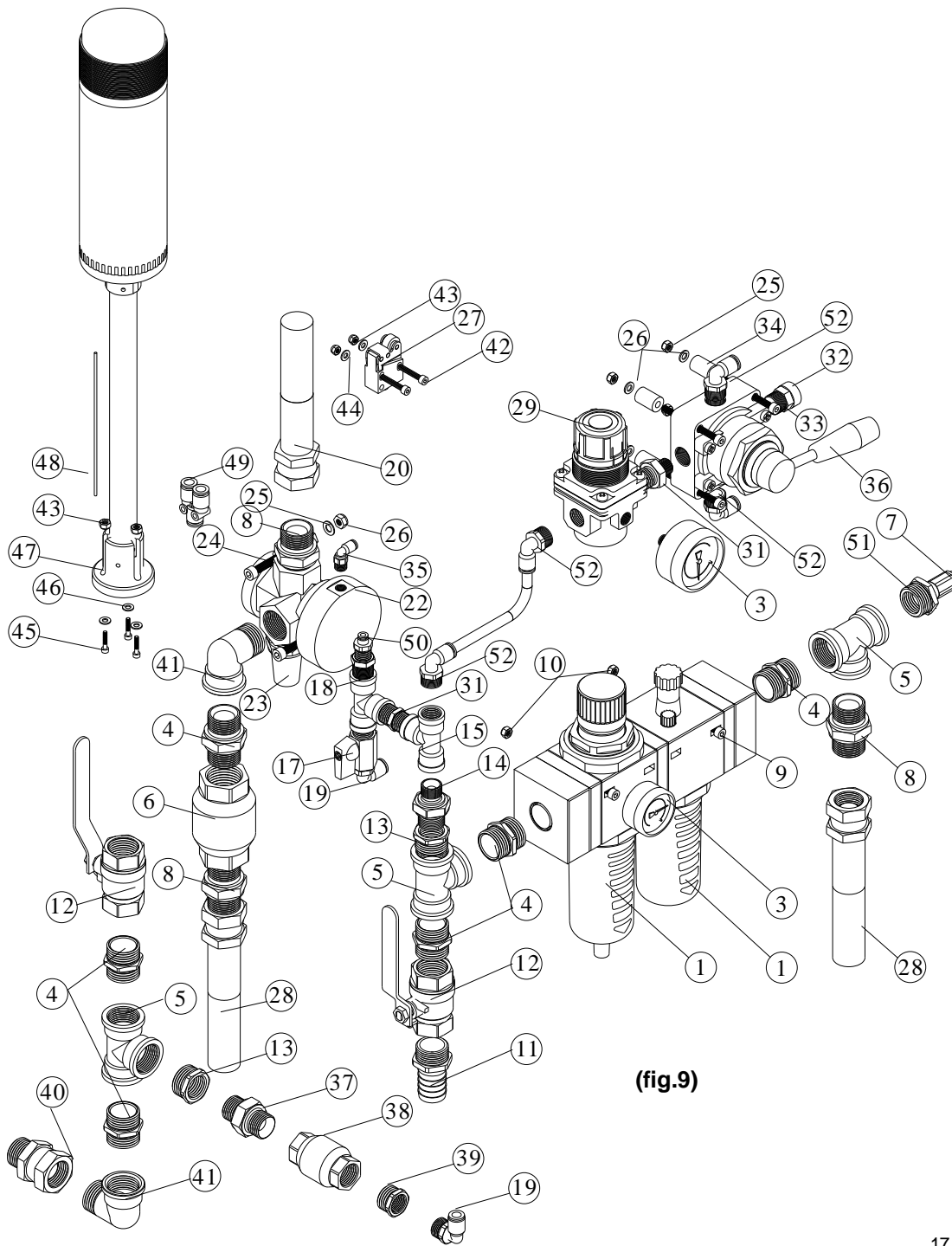

(fig.9)



TECHNICAL DATA

Pressure ratio	45:1
Max. Fluid outlet pressure	315 bar
Max. Air inlet pressure	7 bar
Air inlet to the pump	3/4"
Fluid outlet	3/4"
Flow rate	261 cc/cycle
Joints plate follower	EPDM
Diameter of follower plate	570 mm
Weight	260 kg

Typical applications: - Lubricants

- Inks
- Sealants
- Adhesives

WARRANTY

M.B.P., will any repairs necessary during the first 12 months after purchase of a new unit, with the exceptions shown under 1 and 2 below, and under the conditions shown in item 3.

- 1.- Damage caused by external abuse, customer negligence, or failure to operate the unit in accordance with the instructions supplied with the unit.
- 2.- Normal maintenance items.
- 3.- Within the first 12 months after purchase, M.B.P. will pay 100% of the cost of covered repairs.

In no case will M.B.P. liability extend beyond repair or replacement of the equipment. Such liability is limited to the amount of the original purchase price paid for the unit, minus a reasonable deduction for the time the unit has been in service. It is the responsibility of the purchaser under this warranty to ship or deliver the failed paint sprayer to the authorized service center at the purchaser's expense. Parts or components covered under this warranty may either be repaired or replaced at M.B.P. option.

Equipment not covered by M.B.P. warranty. Accessories or components of equipment sold by M.B.P. that are not manufactured by M.B.P. are subject to the warranty, if any, of their manufacturer. M.B.P. will provide purchaser with reasonable assistance in making such claims.

The Industry Department of The Basque Government, states that all electric and pneumatic airless equipment manufacture by M.B.P. S.L., follows the "CE" standards under the number 83/392/CEE.

