



INSTRUCTIONS AND PARTS LIST

This instruction manual contains IMPORTANT WARNINGS AND INSTRUCTION THAT MUST BE READ BEFORE OPERATING THE PUMP

MAGNUS 8000 HYDRAULIC



INDEX:

SAFETY WARNINGS	2
OPERATION	4
CLEANUP	6
MAINTENANCE	7
TROUBLESHOOTING GUIDE	9
TECHNICAL DATA	10
PARTS DRAWING AND LIST	10
ACCESORIES	14
STANDARD SPRAY TIPS	15
WARRANTY	16

SAFETY WARNINGS***ATTENTION***

This equipment generates very high fluid pressure. High pressure spray can cause serious injury. Read and understand all instructions before operating.

Never point the spray gun at anyone or at any part of the body.

Never put hand, fingers over the spray tip.

Always have the tip guard in place on the spray gun while spraying.

High pressure fluid in the hoses can be very dangerous. If the hose develops a leak, split or rupture due to any kind of wear, damage or misuse, the high pressure spray emitted from it can cause a fluid injection injury or other serious bodily injury or property damage.

Never use a damaged hose

Tighten all fluid connections securely before each use. High pressure fluid can dislodge a loose coupling or allow high pressure spray to be emitted from the coupling.

Proper hose grounding continuity is essential to maintaining a grounded spray system.

If any fluid appears to penetrate your skin, get emergency medical care at once. Do not treat as a simple cut. Tell the doctor exactly what fluid was injected.

All chemicals used in the pump must be compatible with the wetted parts of the pump.

PRESSURE HAZARD

This pump can develop 240 bar working pressure. Be sure that all spray equipment and accessories used are rated to withstand this pressure. Do not exceed the maximum working pressure of any component or accessory used in the system.

FIRE OR EXPLOSION HAZARD

Static electricity is created by the flow of fluid through the pump and hose. If every part of the spray equipment is not properly grounded, sparking may occur and the system may become hazardous. Sparking may also occur when plugging in or unplugging a power supply cord. Sparks can ignite fumes from solvents and the fluid being sprayed, dust particles, whether you are spraying indoors or outdoors, and can cause a fire or explosion.

If you experience any static sparking or even a slight shock while using the equipment, stop spraying immediately. Check the system for proper grounding. Do not use the system again until the problem has been identified and corrected.

GAS ENGINE (WHERE APPLICABLE)

Always place pump outside of structure in fresh air. Keep all solvents away from the engine exhaust. Never fill fuel tank with a running or hot engine. Hot surface can ignite spilled fuel. Always attach ground wire from pump unit to a grounded object, such as a metal water pipe. Refer to engine owner's manual for complete safety information.

PRESSURE RELIEF PROCEDURE

To reduce the risk of serious bodily injury, including fluid injection, splashing fluid or solvent in the eyes or on the skin, or injury from moving parts or electric shock, always follow this procedure whenever you shut off the sprayer, when checking or servicing any part of the spray system, when installing, cleaning or changing spray tips, and whenever you stop spraying:

- Engage the gun safety latch
- Turn the ON/OFF switch to OFF (red)
- Unplug the power supply cord.
- Disengage the gun safety latch. Hold a metal part of the gun to the side of a grounded metal pail, and trigger the gun to relieve pressure.
- Engage the gun safety latch
- Open the pressure drain valve, having a container ready to catch the drainage

GROUNDING INSTRUCTIONS

Electric models must be grounded. In the event of an electrical short circuit, grounding reduces the risk of electric shock by providing an escape wire for the electric current. This product is equipped with a cord having a grounding wire with an appropriate grounding plug. The plug must be plugged into an outlet that is properly installed and grounded in accordance with all local codes and ordinances.

DANGER -Improper installation of the grounding plug can result in a risk of electric shock. If repair or replacement of the cord or plug is necessary, do not connect the green grounding wire to either flat blade terminal. The wire with insulation having a green outer surface with or without yellow stripes is the grounding wire and must be connected to the grounding pin.

NOTE:

Before starting to work the pump must be connected to ground. The pump must be connected to ground with a ground wire which is supplied with the pump (4mm² of section and a clamp).

GASOLINE ENGINE SAFETY

- Honda engines are designed to give safe and dependable service if operated according to instructions. Read and understand the Honda Owner's Manual before operating the engine. Failure to do so could result in personal injury or equipment damage.
- To prevent fire hazards and to provide adequate ventilation, keep the engine at least 1 meter (3 feet) away from buildings and other equipment during operation. Do not place flammable objects close to the engine.
- Children and pets must be kept away from the area of operation due to a possibility of burns from hot engine components or injury from any equipment the engine may be used to operate.
- Know how to stop the engine quickly, and understand the operation of all controls. Never permit anyone to operate the engine without proper instructions.
- Gasoline is extremely flammable and is explosive under certain conditions.
- Refuel in a well-ventilated area with the engine stopped. Do not smoke or allow flames or sparks in the refueling area or where gasoline is stored.
- Do not overfill the fuel tank. After refueling, make sure the tank cap is closed properly and securely.
- Be careful not to spill fuel when refueling. Fuel vapor or spilled fuel may ignite. If any fuel is spilled, make sure the area is dry before starting the engine.
- Never run the engine in an enclosed or confined area. Exhaust contains poisonous carbon monoxide gas; exposure may cause loss of consciousness and may lead to death.
- The muffler becomes very hot during operation and remains hot for a while after stopping the engine. Be careful not to touch the muffler while it is hot. To avoid severe burns or fire hazards, let the engine cool before transporting it or storing it indoors.
- Never ship/transport unit with gasoline in the tank.

OPERATION

- Attach and airless spray gun to the spray hose. Do not attach the tip to the spray gun yet. Remove the tip if it is already attached.
- Check the hydraulic fluid level daily before starting the unit. The hydraulic fluid level should be at the "Full" mark, on the dipstick.
- For gas models, check the engine oil level daily before starting the unit. The gasoline engine oil level is determined by the engine manufacturer.
- Place the suction pipe into a container of solvent/water.
- Place the bleed hose into a metal waste container.
- Set the pressure to minimum by turning the pressure control knob fully counterclockwise.
- Open the hydraulic shut-off valve located on the hydraulic pressure hose. The handle should be in line with the hose.
- Open the bleed valve by turning it fully counterclockwise.
- Start the engine or turn on the electric motor.
 - a) To start the gas engine.
 - Move the fuel valve lever to the open position
 - Move the throttle lever to its middle point
 - Move the choke lever to the closed position for a cold engine or to the open position for a warm engine.
 - Turn the engine switch to the ON position
 - Pull the starter rope briskly until the engine starts.
 - b) To start the electric motor, move the ON/OFF switch to the ON position
- Turn the pressure control knob clockwise approximately 1/3 of the way down to increase pressure until the sprayer cycles evenly and solvent flows freely from the bleed hose.
- Allow the sprayer to run for 15-30 seconds to flush the test fluid out through the bleed hose and into the waste container.
- Turn off the unit
 - a) To turn off the gas engine
 - Set the pressure to minimum by turning the pressure control knob fully counterclockwise.
 - Move the throttle lever to the slow position.
 - Turn the engine switch to the OFF position.

- b) To turn off the electric motor.

Set the pressure to minimum by turning the pressure control knob fully counterclockwise.

Move the ON/OFF switch to the OFF position.

PREPARING TO PAINT

Before painting, it is important to make sure that the fluid in the system is compatible with the paint that is going to be used.

NOTE:

Incompatible fluids and paint may cause the valves to become stuck closed, which would require disassembly and cleaning of the sprayer's fluid suction.



CAUTION

Always keep the trigger lock on the spray gun in the locked position while preparing the system.

- Place the suction pipe into a container of the appropriate solvent.

NOTE:

If you are spraying a water-based latex, flush with warm, clean water. If you are using any other material, check with the material manufacturer for a compatible solvent.

- Place the bleed hose into a metal waste container.
- Set the pressure to minimum by turning the pressure control knob fully counterclockwise.
- Open the hydraulic shut-off valve located on the hydraulic pressure hose. The handle should be in line with the hose.
- Open the bleed valve by turning it fully counterclockwise.
- Start the engine or turn on the electric motor.
 - a) To start the gas engine.
 - Move the fuel valve lever to the open position
 - Move the throttle lever to its middle point
 - Move the choke lever to the closed position for a cold engine or to the open position for a warm engine
 - Turn the engine switch to the ON position
 - Pull the starter rope briskly until the engine starts.
 - b) To start the electric motor, move the ON/OFF switch to the ON position

- Turn the pressure control knob clockwise approximately 1/3 of the way down to increase pressure until the sprayer cycles evenly and solvent flows freely from the bleed hose.
- Allow the sprayer to run for 15-30 seconds to flush the test fluid out through the bleed hose and into the waste container.
- Turn off the unit
 - a) To turn off the gas engine
 - Set the pressure to minimum by turning the pressure control knob fully counterclockwise.
 - Move the throttle lever to the slow position.
 - Turn the engine switch to the OFF position.
 - b) To turn off the electric motor.
 - Set the pressure to minimum by turning the pressure control knob fully counterclockwise.
 - Move the ON/OFF switch to the OFF position.

NOTE: Make sure that the spray gun does not have a tip or tip guard installed.

- Close the bleed valve by turning it fully clockwise.
- Start the engine or turn on the electric motor.
- Turn the pressure control knob clockwise approximately 1/3 of the way down to increase pressure.
- Unlock the gun by turning the gun trigger lock to the unlocked position.
- Trigger the gun into the metal waste container until the old solvent is gone and fresh solvent is coming out of the gun.
- Lock the gun by turning the gun trigger lock to the locked position.
- Set down the gun and increase the pressure by turning the pressure control knob slowly clockwise.
- Check the entire system for leaks. If leaks occur, follow the "Pressure Relief Procedure" in this manual before tightening any fitting or hoses.
- Follow the "Pressure Relief Procedure" in this manual before changing from solvent to paint.



WARNING

Be sure to follow the pressure relief procedure when shutting the unit down for any purpose, including servicing or adjusting any part of the spray system, changing or cleaning spray tips, or preparing for cleanup.

PAINTING

- Place the suction pipe into a container of paint.
- Place the bleed hose into a metal waste container.
- Set the pressure to minimum by turning the pressure control knob fully counterclockwise.
- Open the hydraulic shut-off valve located on the hydraulic pressure hose. The handle should be in line with the hose.
- Open the bleed valve by turning it fully counterclockwise.
- Start the engine or turn on the electric motor.
 - a) To start the gas engine.
 - Move the fuel valve lever to the open position
 - Move the throttle lever to its middle point
 - Move the choke lever to the closed position for a cold engine or to the open position for a warm engine
 - Turn the engine switch to the ON position
 - Pull the starter rope briskly until the engine starts.
 - b) To start the electric motor, move the ON/OFF switch to the ON position
- Turn the pressure control knob clockwise approximately 1/3 of the way down to increase pressure until the sprayer cycles evenly and paint flows freely from the bleed hose.
- Turn off the unit
 - a) To turn off the gas engine.
 - Set the pressure to minimum by turning the pressure control knob fully counterclockwise.
 - Move the throttle lever to the slow position.
 - Turn the engine switch to the OFF position.
 - b) To turn off the electric motor.
 - Set the pressure to minimum by turning the pressure control knob fully counterclockwise.
 - Move the ON/OFF switch to the OFF position.
- Remove the bleed hose from the waste container and place it into the container of paint.
- Close the bleed valve by turning it fully clockwise.
- Start the engine or turn on the electric motor.
- Turn the pressure control knob clockwise approximately 1/3 of the way down to increase pressure.
- Unlock the gun by turning the gun trigger lock to the unlocked position.



WARNING

Ground the gun by holding it against the edge of the metal container while flushing. Failure to do so may lead to a static electric discharge, which may cause a fire.

- Trigger the gun into the metal waste container until all air and solvent is flushed from the spray hose and paint is flowing freely from the gun.
- Lock the gun by turning the gun trigger lock to the locked position.
- Turn off the unit.
- Attach tip guard and tip to the gun as instructed by the tip guard or tip manuals.



WARNING

POSSIBLE INJECTION HAZARD. Do not spray without the tip guard in place. Never trigger the gun unless the tip is in either the spray or the unclog position. Always engage the gun trigger lock before removing, replacing or cleaning tip.

- Start the engine or turn on the electric motor.
- Increase the pressure by turning the pressure control knob slowly clockwise and test the spray pattern on a piece of cardboard. Adjust the pressure control knob until the spray from the gun is completely atomized.

NOTE:

Turning the pressure up higher than needed to atomize the paint will cause premature tip wear and additional overspray.

PRESSURE RELIEF PROCEDURE



WARNING

Be sure to follow the pressure relief procedure when shutting the unit down for any purpose, including servicing or adjusting any part of the spray system, changing or cleaning spray tips, or preparing for cleanup.

- Lock the gun by turning the gun trigger lock to the locked position.
- Turn off the unit
 - a) To turn off the gas engine
 - Set the pressure to minimum by turning the pressure control knob fully counterclockwise
 - Move the throttle lever to the slow position
 - Turn the engine switch to the OFF position.
 - b) To turn off the electric motor.
 - Set the pressure to minimum by turning the pressure control knob fully counterclockwise.
 - Move the ON/OFF switch to the OFF position.
- Close the hydraulic shut-off valve on the hydraulic pressure hose.
- Unlock the gun by turning the gun trigger lock to the unlocked position.
- Hold the metal part of the gun firmly to the side of a metal waste container to ground the gun and avoid a build up of static electricity.
- Trigger the gun to remove any pressure that may still be in the hose.
- Lock the gun by turning the gun trigger lock to the locked position.
- Place the bleed hose into the metal waste container.
- Open the bleed valve by turning it fully counterclockwise.

CLEANUP



WARNING

Special cleanup instructions for use with flammable solvent:

- Always flush spray gun preferably outside and at least one hose length from spray pump.
- If collecting flushed solvents in a one gallon metal container, place it into a empty five gallon container, then flush solvents.
- Area must be free of flammable vapors.
- Follow all cleanup instructions.



CAUTION

The sprayer, hose, and gun should be cleaned thoroughly after daily use. Failure to do so permits material to build up, seriously affecting the performance of the unit.



WARNING

Always spray at minimum pressure with the gun nozzle tip removed when using mineral spirits or any other solvent to clean the sprayer, hose, or gun. Static electricity buildup may result in a fire or explosion in the presence of flammable vapors.

- Follow the "Pressure Relief Procedure" found in the Operation section of this manual.
- Remove the gun tip and tip guard and clean with a brush using the appropriate solvent.
- Place the suction pipe into a container of the appropriate solvent.



CAUTION

Use only compatible solvents when cleaning out oil based enamels, lacquers, coal tar, and epoxies. Check with the fluid manufacturer for the recommended solvent.

- Place the bleed hose into the metal waste container.
- Set the pressure to minimum by turning the pressure control knob fully counterclockwise.
- Open the hydraulic shut-off valve located on the hydraulic pressure hose. The handle should be in line with the hose.
- Open the bleed valve by turning it fully counterclockwise.
- Start the engine or turn on the electric motor.
- Allow the solvent to circulate through the unit and flush the paint out of the bleed hose into the metal waste container.
- Turn off the unit.
- Close the bleed valve by turning it fully clockwise.
- Star the engine or turn on the electric motor.



WARNING

Ground the gun by holding it against the edge of the metal container while flushing. Failure to do so may lead to a static electric discharge, which may cause a fire.

- Trigger the gun into the metal waste container until the paint is flushed out off the hose and solvent is coming out of the gun.
- Continue to trigger the spray gun into the waste container until the solvent coming out of the gun is clean.

NOTE: For long-term or cold weather storage, pump mineral spirits through the entire system.

- Follow the "Pressure Relief Procedure" found in the Operation section of this manual.
- Store the unit in a clean, dry area.

Do not store the unit under pressure.

Cleaning a Clogged Tip

- 1- Follow the "Pressure Relief Procedure" in the Operation section on this manual.
- 2- In the tip clogs, rotate the tip handle 180° until the arrow on the handle is facing the opposite of the spray direction and the handle clicks in the reverse position.
- 3- Trigger the gun once so that the pressure can blow the clog out. NEVER use the tip in the reverse position for more than ONE trigger pull at a time. This procedure can be repeated until the tip is free of clogging.



WARNING

The flow from the spray tip is at very high pressure. Contact with any body part may be dangerous. Do not place finger on gun outlet. Do not point the gun at any person. Never operate the spray gun without the proper tip guard.

MAINTENANCE



WARNING

Before proceeding, follow the Pressure Relief Procedure outlined previously in this manual. Additionally, follow all other warnings to reduce the risk of an injection injury, injury from moving parts or electric shock. Always unplug the sprayer before servicing.

DAILY MAINTENANCE

Two daily procedures are required for routine operator maintenance on this unit:

- Lubricating the upper packing.
- Cleaning the rock catcher.

Lubricating the Upper Packings

- Clean out the paint that has seeped past the upper packings into the packing oil reservoir above the fluid section.
- Fill the packing oil reservoir 1/2 full with Piston Lube supplied by the factory. This will extend packing life.

NOTE: Do not over -fill the reservoir so that it overflows and drips into the paint.

MAINTAINING THE HYDRAULIC SYSTEM



CAUTION

Use of MBP Hydraulic Fluid is mandatory in the hydraulic system. Do not use any other hydraulic fluid. Use of any other hydraulic fluid may seriously damage the hydraulic system and will void the warranty.

- 1- Check the hydraulic fluid daily. It should be at the "Full" mark on the dipstick. If it is low, add only MBP Hydraulic Fluid. Never add or change hydraulic fluid except in a clean, dust-free area. Contamination of the hydraulic fluid will shorten hydraulic pump life and may void warranty.
- 2- Change the hydraulic fluid every twelve months. Drain the old fluid from the tank. Start the unit at just enough pressure to operate the fluid section. Run the unit at this low pressure for at least 5 minutes. This removes air from the system. Check the fluid level after this procedure.
- 3- The hydraulic system has an external, replaceable hydraulic filter. Change the filter every twelve months.

BASIC ENGINE MAINTENANCE (GAS ENGINE)

- For detailed engine maintenance and technical specifications refer to the separate gasoline engine manual.
- All service to the engine should be performed by an authorized Honda Power Equipment dealer.

Daily

- Check engine oil level, and fill as necessary.
- Check gasoline level, and fill as necessary.



WARNING

Always follow the fueling procedure outlined earlier in this manual.

First 20 Hours

- 1° Change engine oil.

Every 100 Hours

- 1° Change engine oil.
- 2° Clean the sediment cup.
- 3 °Clean and re-gad the spark plug.
- 4° Clean the spark arrestor.

Weekly

Remove the air filter cover and clean the element. In very dusty environments, check the filter daily. Replace the element as needed. Replacement elements can be purchased from your local Honda dealer.

Engine Operation and Service

- 1° Clean and oil air filter pad on gasoline engine every 25 hours or once weekly. Do not permit the air intake screen around the fly wheel of the gas engine to load up with paint or trash. Clean it regularly. The service life and efficiency of the gas engine model depends upon keeping the gasoline engine running properly. Change the oil in the engine every 100 hours. Failure to observe this may result in engine overheating. Consult the engine manufacturer's service manual provided.
- 2° To conserve fuel, service life, and efficiency of the unit, always operate the gasoline engine at the lowest RPM at which it runs smoothly without laboring and delivers the amount required for the particular painting operation. Higher RPM does not produce higher working pressure. The gasoline engine is connected to the hydraulic pump by a pulley combination designed to produce full paint delivery of 1.2 GPM at maximum RPM
- 3° The warranty on gasoline engines or electric motors is limited to the original manufacturer

TROUBLESHOOTING GUIDE FLUID SECTION

TROUBLE	POSSIBLE CAUSE	SOLUTION
Pump delivers on upstroke only or goes up slowly and down fast.	<ul style="list-style-type: none"> ■ Lower foot valve ball is not seating due to trash or wear. ■ Material too viscous to siphon. ■ Air leaking in on siphon side or damaged siphon hose. Siphon may be too small for heavy material. 	<ul style="list-style-type: none"> ■ Remove foot valve assembly. Clean and inspect. Test foot valve by filling with water; if ball fails to seal the seat, replace ball. ■ Thin material, contact manufacturer for proper thinning procedures. ■ Tighten all connections between pump and paint container. If damaged, replace. Switch to larger diameter siphon set.
Pump delivers on down stroke only or goes up fast and down slowly.	<ul style="list-style-type: none"> ■ Upper ball is not seating due to trash or wear. ■ Lower packing set is worn. 	<ul style="list-style-type: none"> ■ Check upper seat and ball with water. If ball fails to seal, replace seat. ■ Replace packing set if worn.
Pump moves up and down fast, delivering material.	<ul style="list-style-type: none"> ■ Material container is empty or material is too thick to flow through siphon hose. ■ Bottom ball stuck to foot valve seat. ■ Siphon hose is kinked or loose. 	<ul style="list-style-type: none"> ■ Refill with new material. If too thick, remove siphon hose, immerse fluid section in material, and start pump to prime. Add thinner to material. Change to bigger siphon set. Open bleed valve to remove air and restart pump. ■ Remove foot valve. Clean ball and seat. ■ Straighten.
Pump moves up and down slowly when spray gun is shut off.	<ul style="list-style-type: none"> ■ Loose connections. Bleed valve is open partially or bleed valve is worn. Lower packing seat is worn. ■ Upper and/or lower ball not seating. 	<ul style="list-style-type: none"> ■ Check all connections between pump and gun. Tighten as necessary. If material is flowing from bleed hose, close bleed valve or replace, if necessary. Should none of the above be evident, replace lower packing. ■ Reseat balls by cleaning.
Not enough fluid pressure at gun.	<ul style="list-style-type: none"> ■ Spray tip is worn. ■ Outlet filter or gun filter is clogged. ■ Low voltage and/or inadequate amperage. ■ Hose size or length is too small or too long. 	<ul style="list-style-type: none"> ■ Replace. ■ Clean or replace filter. ■ Check electrical service. Correct as required. ■ Increase hose size to minimize pressure drop through hose and/or reduce hose length.
Pump chatters on up or down stroke.	<ul style="list-style-type: none"> ■ Solvent has caused upper packing to swell. 	<ul style="list-style-type: none"> ■ Replace packing.

TROUBLESHOOTING GUIDE FLUID SECTION

TROUBLE	POSSIBLE CAUSE	SOLUTION
Oil motor stalls at bottom (no unusual heat problems).	<ul style="list-style-type: none"> ■ Fluid pump piston seat unthreaded. ■ Valve sticking or oil motor trip rod shifter assembly separated. 	<ul style="list-style-type: none"> ■ If connecting rod is okay, remove cylinder head plug and pop valve down. Replace plug and start machine. If machine cycles up and stops at bottom again, then problem is piston seat on fluid pump. Check piston seat. Repair or replace as necessary. If piston seat is okay and problem does not change, check oil motor. ■ Remove valve and check for scratches and rough movement when sliding it up and down. Replace valve and spool in this condition. Check trip rod for possible separation and spool in this condition. Check trip rod for possible separation.
Oil motor stalls at top (no unusual heat problems).	<ul style="list-style-type: none"> ■ Valve sticking. ■ Broken spring retainer (valve rod assembly). ■ Broken spring or valve rod. ■ Air in hydraulic motor. ■ Air in fluid pump. 	<ul style="list-style-type: none"> ■ Remove valve and check for scratches and rough movement when sliding it up and down. Replace valve and spool in this condition. ■ Replace valve rod assembly. ■ Replace valve rod assembly ■ Reset valve. Purge Air, generally accomplished by low pressure cycling of motor/pump assembly for 5-10 minutes. Check for causes of air introduction: <ul style="list-style-type: none"> -Loose fittings in tank. -Loose fittings on hydraulic pump. -Loose hose connections. -Low oil in reservoir. ■ Stall at top can occur randomly when fluid pump picks up air. Reset valve. Avoid air in the fluid pump.

PARTS LIST

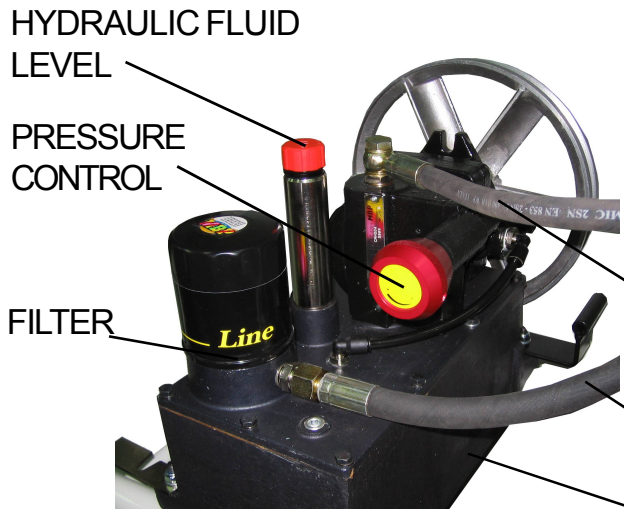
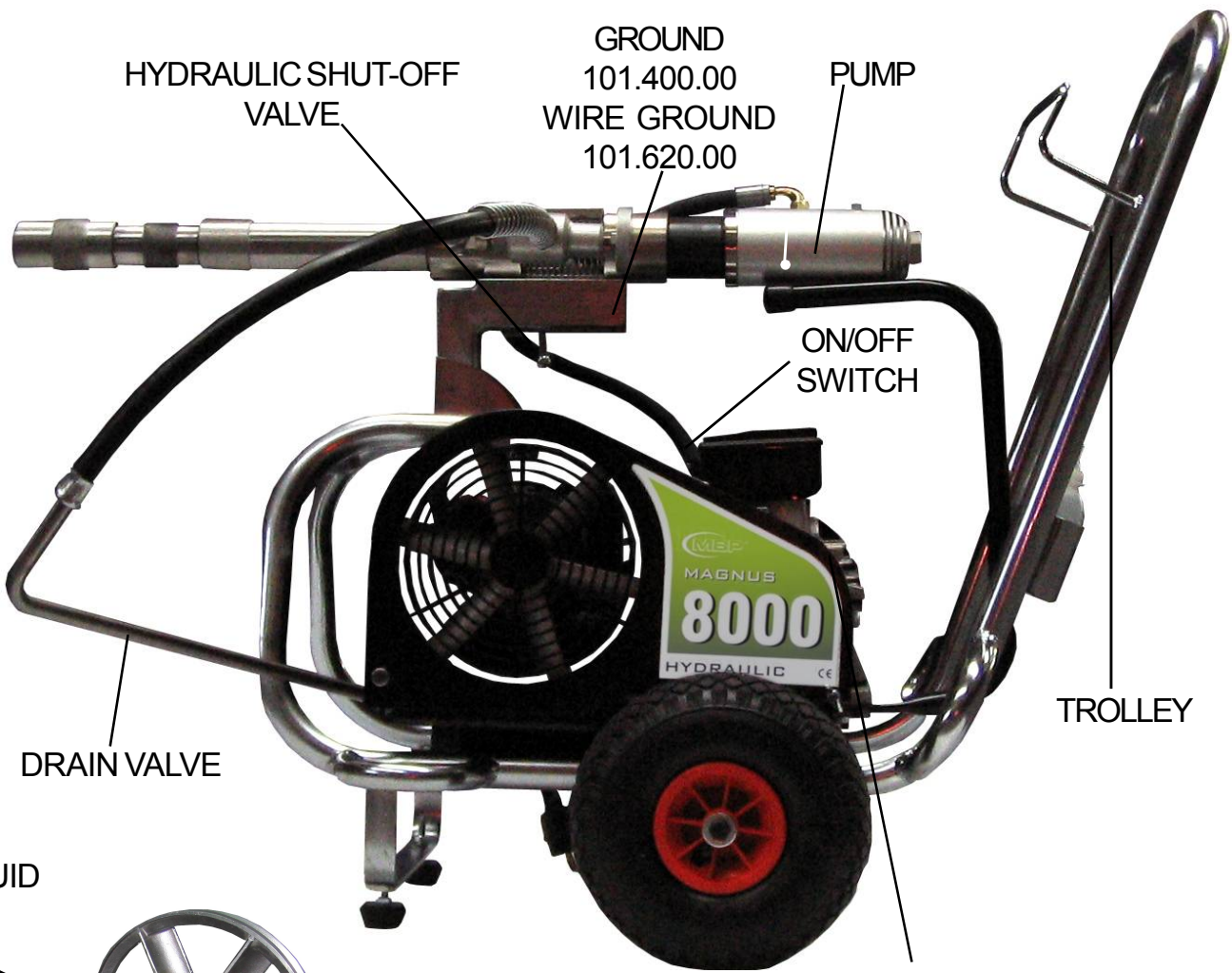

INLET HYDRAULIC SYSTEM
 OUTLET HYDRAULIC SYSTEM
 HYDRAULIC TANK

TECHNICAL DATA

MAGNUS 8000

•Delivery:	5,7 l/min.
•Max. Pressure:	228bar
•Max. Tip Size:	1gun-0,036''
	2 guns-0,026''
•Electric Motor	3HP (220V-50Hz.)
•Weight:	66 Kgs.
•Packaging dimesions:	84x120x108cm.

•Delivery:	6,4 l/min.
•Max. Pressure:	228bar
•Max. Tip Size:	1gun-0,043''
	2 guns-0,033''
•Motor:	Gasoline 5,5HP
•Weight:	72Kgs.
•Packaging dimesions:	84x120x108cm.

MOTOR

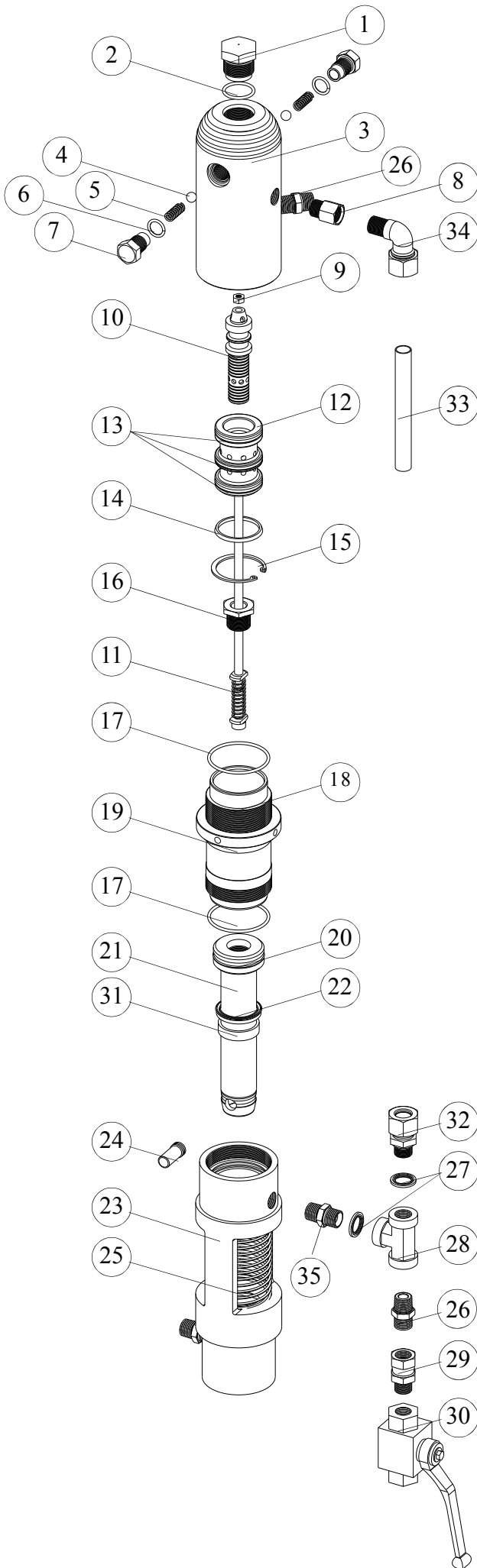

N°	REF.	DESCRIPTION	Q
1	103.110.04	PLUG	1
2	CJT.162	O-RING	1
3	103.110.01	CYLINDER	1
4	CBO.009	BALL	2
5	103.110.03	SPRING	2
6	CJT.161	O-RING	2
7	103.110.02	PLUG	2
8	103.200.01	NIPPLE	1
9	CTU.107	NUT	1
*10	103.120.02	VALVE	1
11	103.120.00	SHAFT	1
*12	103.110.05	DISTRIBUTOR	1
13	CJT.163	O-RING	3
14	103.110.06	WASHER	1
15	CAR.127	WASHER	1
16	103.120.06	NUT	1
17	CJT.160	O-RING	2
18	103.100.02	CYLINDER	1
19	103.100.01	NUT	1
20	CAB.021	JOINT	1
21	103.121.00	BASE CYLINDER	1
22	CAB.020	JOINT	1
23	103.300.01	BODY CYLINDER	1
24	103.120.08	PIN	1
25	103.300.02	SPRING	1
26	G.500.04	NIPPLE	2
27	CJT.176	JOINT	2
28	CNA.128	CONECCTOR	1
29	CNA.121	NUT	1
30	CNC.018	VALVE	1
31	103.100.08	GUIDE	1
32	CNA.151	NIPPLE	1
33	103.200.02	PIPE	1
34	CNA.150	ELBOW	1
35	CNA.131	NIPPLE	1

* **KIT 060:** Sold both pcs together.

DISPLACEMENT PUMP

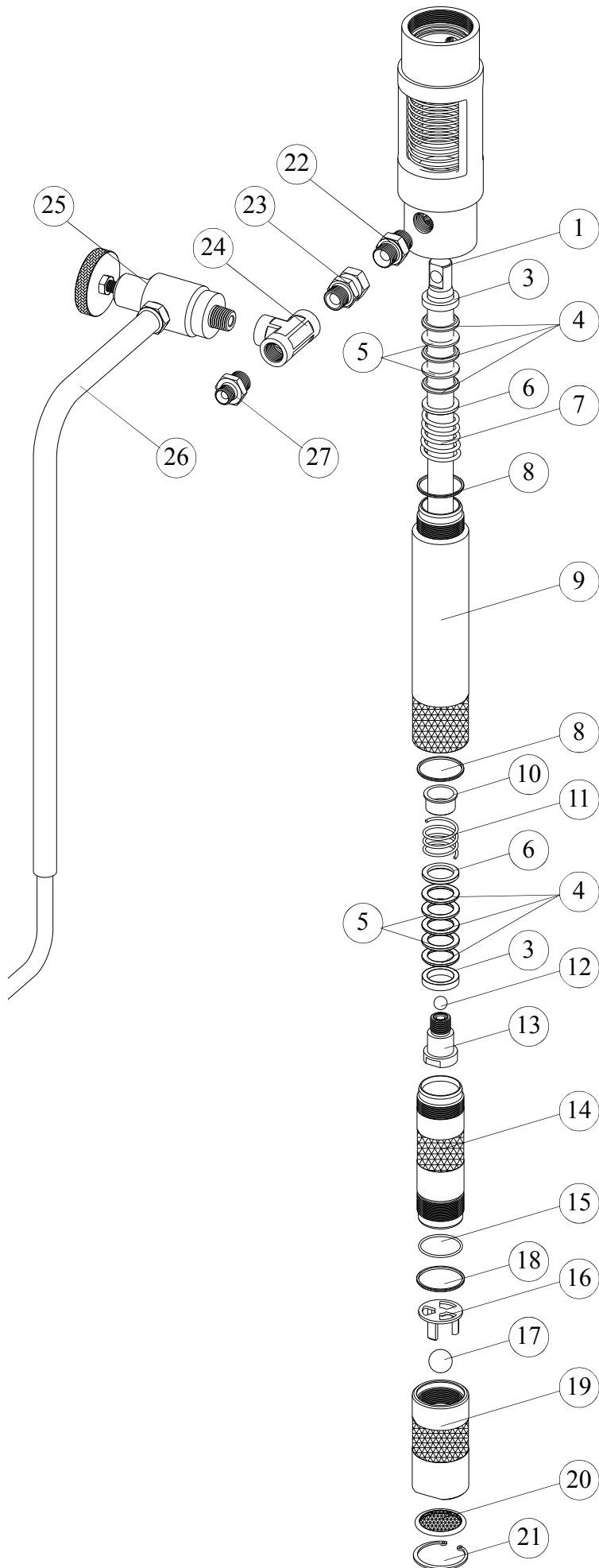

N°	REF.	DESCRIPTION	Q
1	104.200.06	ROD	1
*3	104.240.04	FEMALE GLAND	2
*4	104.240.01	PACKING	6
*5	104.240.02	PACKING	4
*6	104.240.03	MALE GLAND	2
7	104.200.07	SPRING	1
8	104.200.08	JOINT	2
9	104.200.05	CYLINDER	1
10	104.200.02	SPRING SEAT	1
11	104.200.03	SPRING	1
*12	CBO.102	BALL	1
13	104.230.00	PISTON	1
14	104.200.04	CYLINDER	1
15	CJT.042	O-RING	1
16	104.200.01	BALL GUIDE	1
*17	CBO.103	BALL	1
18	104.200.09	JOINT	1
19	104.220.00	VALVE	1
20	104.200.10	FILTER	1
21	CAR.127	WASHER	1
22	CNA.126	NIPPLE	1
23	CNA.127	NUT	1
24	CNA.100	“T”	1
25	104.251.00	VALVE	1
26	104.252.00	PURGE	1
27	CNA.087	NIPPLE	1

* **KIT 049:** Includes packings (up & down) packing glands and balls.

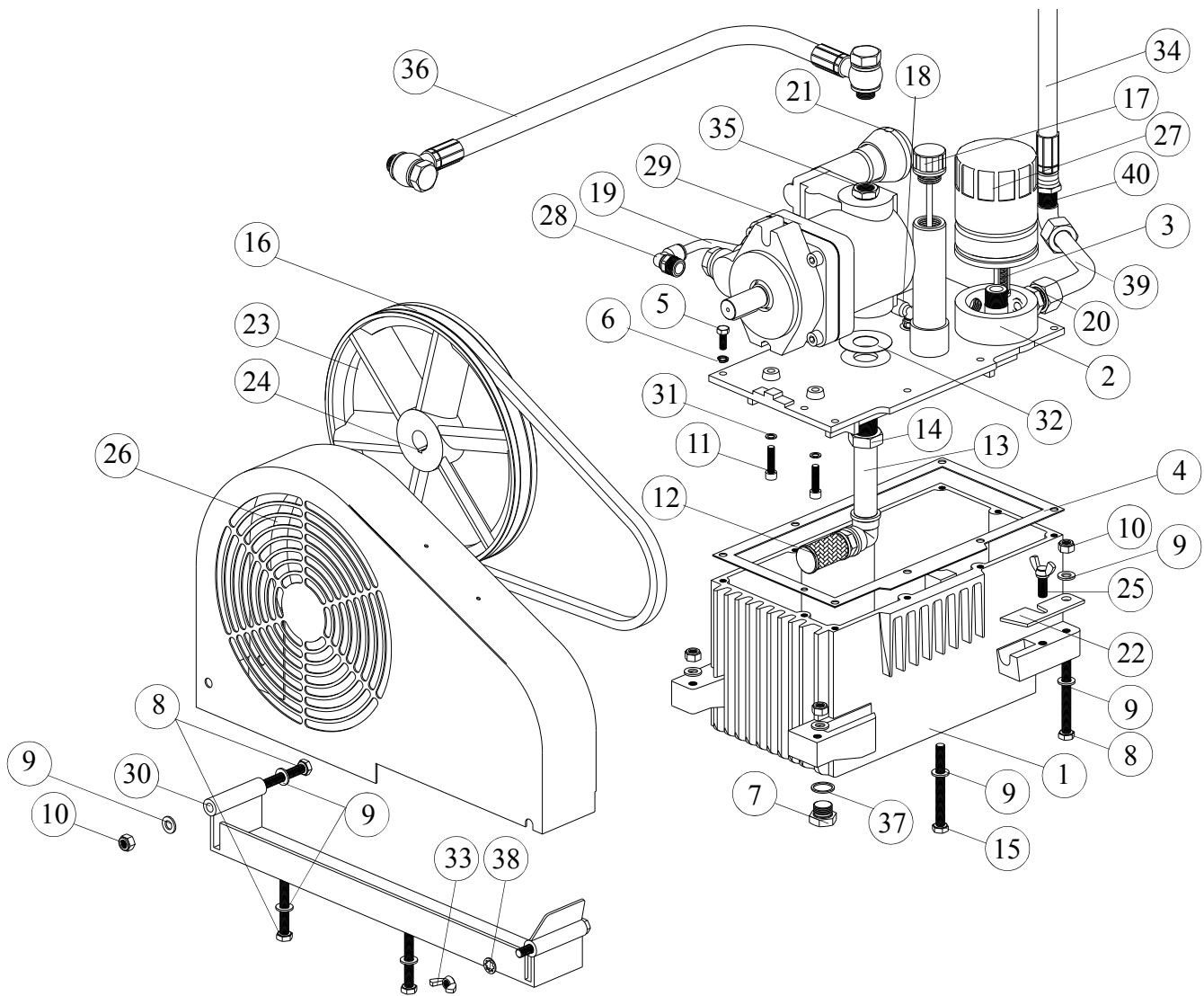

N°	REF.	DESCRIPTION	Q
1	104.600.01	TANK	1
2	104.620.00	COVER	1
3	104.621.00	VALVE	1
4	104.600.02	JOINT	1
5	CTA.011	SCREW	10
6	CAR.052	WASHER	10
7	104.600.14	PLUG	1
8	CTA.014	SCREW	4
9	CAR.006	WASHER	8
10	CTU.106	NUT	4
11	CTB.013	SCREW	2
12	16.313.00	FILTER	1
13	104.622.00	PIPE	1
14	104.600.03	NUT	1
15	CTA.015	SCREW	1
16	CJT.301	BELT	1
17	CMH.002	DIPSTICK	1
18	CNA.065	ELBOW	1
19	104.600.04	PIPE	1
20	CNA.151	NIPPLE	1

N°	REF.	DESCRIPTION	Q
*21	104.600.08	KNOP	1
22	104.600.05	PLATE	1
23	104.600.06	PULLEY	1
24	CTG.021	PIN	1
25	CTA.010	SCREW	1
26	104.640.00	COVER	1
27	CMH.003	FILTER	1
*28	CNA.064	ELBOW	1
*29	CMH.004	PISTON PUMP	1
30	104.630.00	SUPPORT	1
31	CAR.023	WASHER	2
32	104.600.10	JOINT	1
33	CTU.017	NUT	1
34	104.650.00	HOSE	1
*35	104.600.07	NIPPLE	1
36	104.660.00	HOSE	1
37	CAR.015	WASHER	1
38	CAR.251	WASHER	1
39	104.600.15	PIPE	1
40	CNA.150	NIPPLE	1

* KIT 051: Piston Pump

ELECTRIC PUM

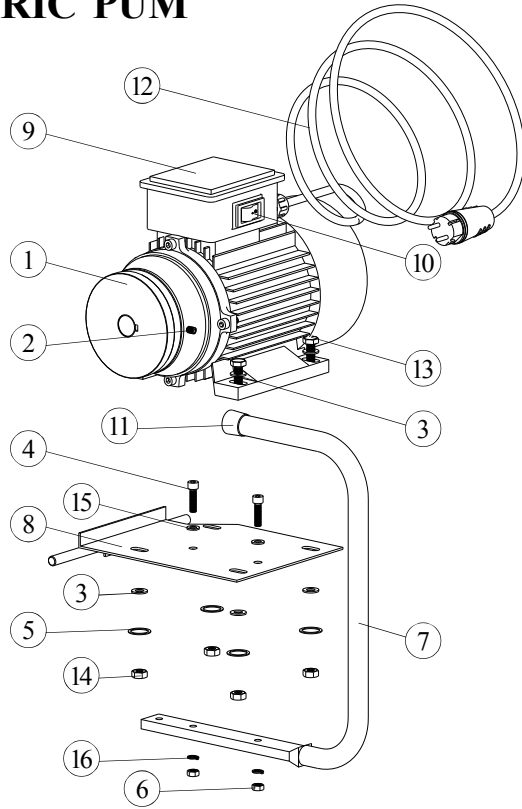

N°	REF.	DESCRIPTION	Q
1	104.700.01	PULLEY	1
2	CTG020	PIN	1
3	CAR.005	WASHER	8
4	CTB.029	SCREW	2
5	CAR.053	WASHER	4
6	CTU.001	NUT	2
7	104.800.02	HANDLE	1
8	104.710.00	PLATE	1
9	CEA.044	MOTOR	1
10	CEA.048	SWITCH ON/OFF	1
11	CAB.003	PLUG	1
12	100.630.00	CABLE	1
13	CTB.037	SCREW	4
14	CTU.003	NUT	4
15	CAR.006	WASHER	2
16	CAR.051	WASHER	2

GASOLINE PUM

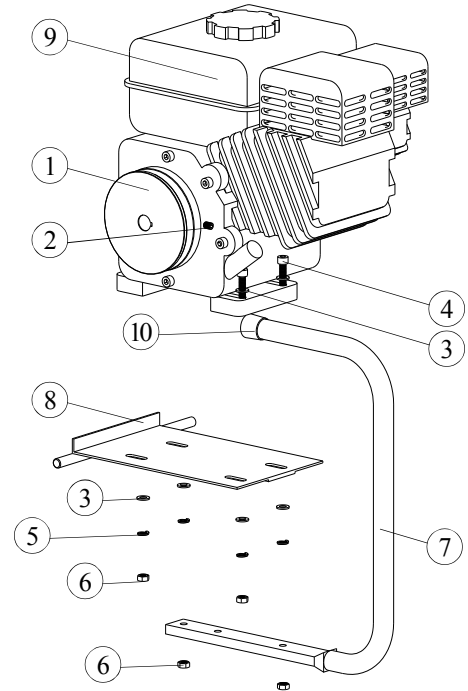

N°	REF.	DESCRIPTION	Q
1	104.800.01	PULLEY	1
2	CTG020	PIN	1
3	CAR.006	WASHER	8
4	CTB.009	SCREW	4
5	CAR.051	WASHER	4
6	CTU.001	NUT	4
7	104.800.02	HANDLE	1
8	104.810.00	PLATE	1
9	CEA.042	MOTOR	1
10	CAB.003	PLUG	1

ACCESSORIES

KIT HP+FILTER+DRAIN VALVE, WHEN SPRAYING PAINTS



REF 104.400.00

J.700.CS (CARBON STEEL) =1,150Kg	
J.700.AL (ALUMINIUM) =0,900Kg	
J.700.CS.L (CARBON STEEL) =1,830Kg	
J.700.AL.L (ALUMINIUM) =1,430Kg	

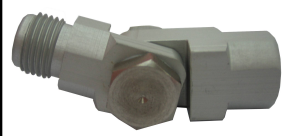

SWIVEL CONNECTOR
REF:J.274
REF:J.274X



STANDARD TIP
REF: 90.XX.XX



AIRLESS GUN FILTER		
REF.	MESH	COLOUR
J.260.01	50	WHITE
J.260.02	100	YELLOW
J.260.03	200	RED



REVERSIBLE BASE
REF:J.790.00



TIP EXTENSIONS
REF: J.271.

STANDARD SPRAY TIPS

ORIFICE SIZE MM / INCHES	FLOW IN LITRES / MIN	FAN WIDTH AT 300 MM.	ORIFICE SIZE MM / INCHES	FLOW IN LITRES / MIN	FAN WIDTH AT 300 MM.
0.48mm .019" 19.20 19.40 19.60	1.36	100-150 200-250 300-350	0.84mm .033" 33.20 33.40 33.60	4.353	100-150 200-250 300-350
0.53mm .021" 21.20 21.40 21.60	1.74	100-150 200-250 300-350	0.89mm .035" 35.20 35.40 35.60	4.958	100-150 200-250 300-350
0.58mm .023" 23.20 23.40 23.60	2.08	100-150 200-250 300-350	0.99mm .039" 39.20 39.40 39.60	6.170	100-150 200-250 300-350
0.63mm .025" 25.20 25.40 25.60	2.49	100-150 200-250 300-350	1.04mm .041" 41.20 41.40 41.60	6.813	100-150 200-250 300-350
0.68mm .027" 27.20 27.40 27.60	2.91	100-150 200-250 300-350	1.09mm .043" 43.20 43.40 43.60	7.532	100-150 200-250 300-350
0.74mm .029" 29.20 29.40 29.60	3.33	100-150 200-250 300-350	1.14mm .045" 45.20 45.40 45.60	8.251	100-150 200-250 300-350
0.79mm .031" 31.20 31.40 31.60	3.86	100-150 200-250 300-350	1.25mm .049" 49.20 49.40 49.60	9.727	100-150 200-250 300-350

WARRANTY

M.B.P., will any repairs necessary during the first 12 months after purchase of a new unit, with the exceptions shown under 1 and 2 below, and under the conditions shown in item 3.

- 1.- Damage caused by external abuse, customer negligence, or failure to operate the unit in accordance with the instructions supplied with the unit.
- 2.- Normal maintenance items.
- 3.- Within the first 12 months after purchase, M.B.P. will pay 100% of the cost of covered repairs.

In no case will M.B.P. liability extend beyond repair or replacement of the equipment. Such liability is limited to the amount of the original purchase price paid for the unit, minus a reasonable deduction for the time the unit has been in service. It is the responsibility of the purchaser under this warranty to ship or deliver the failed paint sprayer to the authorized service center at the purchaser's expense. Parts or components covered under this warranty may either be repaired or replaced at M.B.P. option.

Equipment not covered by M.B.P. warranty. Accessories or components of equipment sold by M.B.P. that are not manufactured by M.B.P. are subject to the warranty, if any, of their manufacturer. M.B.P. will provide purchaser with reasonable assistance in making such claims.

The Industry Department of The Basque Government, states that all electric and pneumatic airless equipment manufacture by M.B.P. S.L., follows the "CE" standards under the number 83/392/CEE.

DECLARACION DE CONFORMIDAD "CE" "EC" DECLARATION OF CONFORMITY

MODELO / MODEL MAGNUS 8000

Este producto cumple con la siguiente directiva de la Comunidad Europea.

This Product complies with the following European Community Directive.

Directiva 2014/34/EU Atex sobre máquinas. (Ex II 2G c T6 X)

Machinery Directive 2014/34/EU Atex Directive. (Ex II 2G c T6 X)

APROBADO POR /

APPROVED BY

AITOR ORTIZ

FECHA / DATE

MBP, S.L. figura inscrita en el Registro Industrial del País Vasco con el N° 01/8030 y cumple los requisitos para el desarrollo de su actividad comercial.

MBP, S.L. is registered in the Industrial Register of the Basque Country with the N° 01/8030.

