

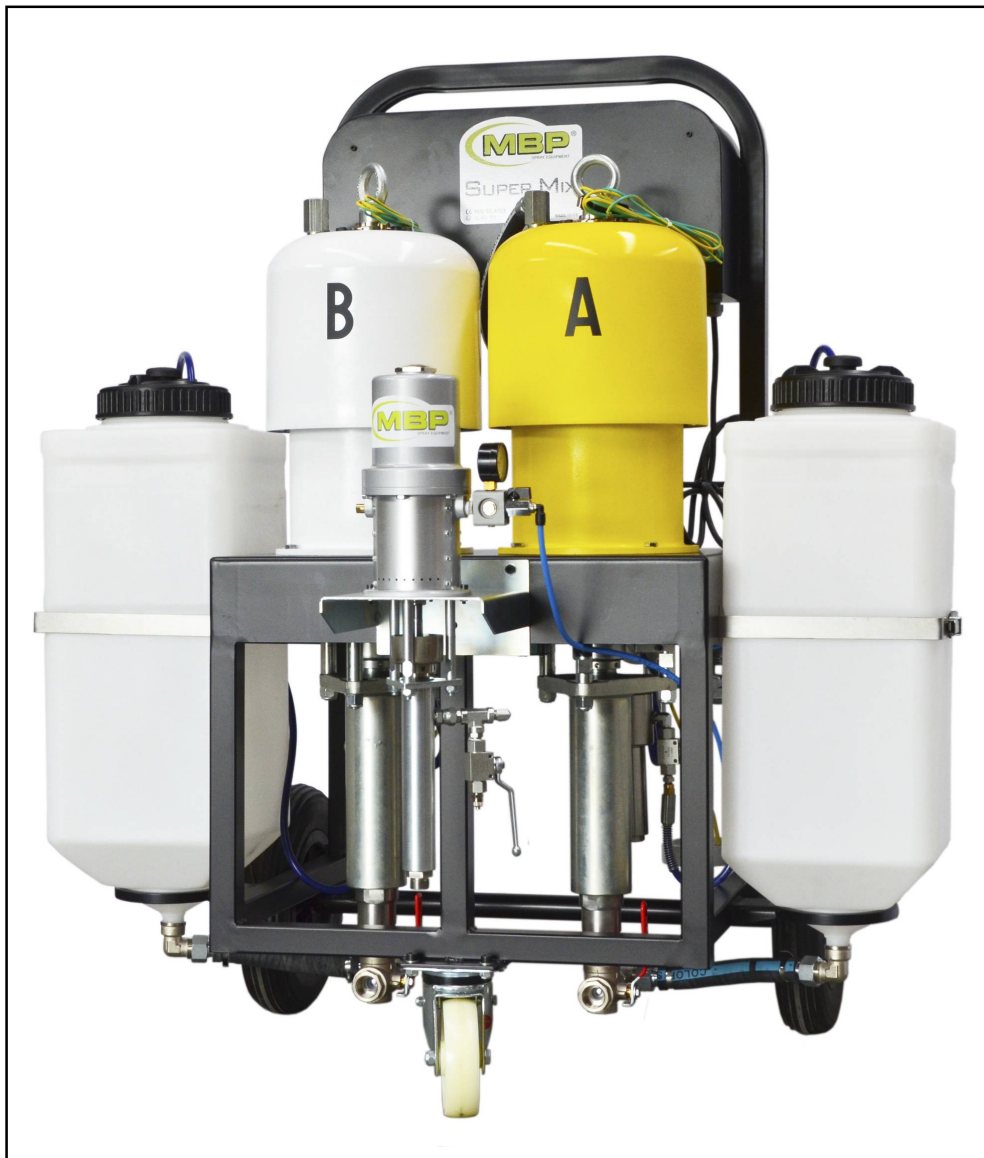

## INSTRUCTIONS AND PARTS LIST

This instruction manual contains IMPORTANT WARNINGS AND INSTRUCTION THAT MUST BE READ BEFORE OPERATING THE PUMP

# SUPER MIX 63



## INDEX

Symbols .....	Pág. 2
Pressure relief procedure .....	Pág. 4
Shutdown and cleaning .....	Pág. 4
Alarms and Troubleshooting guide .....	Pág. 5
Procedure lifting of unit .....	Pág. 7
Electronic diagram .....	Pág. 13
Equipment parts .....	Pág. 14
Pneumatic connections .....	Pág. 15
Metering valve .....	Pág. 16
Fluid manifold .....	Pág. 17
Sensor .....	Pág. 17
Air Motor HD-63 .....	Pág. 18
Displacement pump HD-63.....	Pág. 19
Air Motor TEL 46X .....	Pág. 20
Displacement pump TEL 46X .....	Pág. 21
Airless gun .....	Pág. 22
Conversión of weight ratios to volumetric ratios .....	Pág. 23

## SYMBOLS



### WARNING

THIS SYMBOL ALERTS YOU ABOUT THE POSSIBILITY OF SERIOUS INJURIES OR DEATH IF INSTRUCTIONS ARE NOT FOLLOWED.



### CAUTION

THIS SYMBOL WARNS OF THE POSSIBILITY OF DAMAGE OR DESTRUCTION OF EQUIPMENT IF YOU DO NOT FOLLOW INSTRUCTIONS.



### WARNING



INSTRUCCIONES

### DANGER DUE TO MISUSE OF THE MACHINE

- Incorrect use can cause equipment to malfunction or even shatter and cause accidents.
- Consult the instruction's handbook before using the equipment.
- Use the equipment for its intended purpose.
- In case of doubt to consult with the distributor and not modify the machine.
- Use original spare parts from MBP
- Check periodically the equipment and replace the damaged parts.
- Do not exceed the maximum pressure in the equipment.
- Use solvents and cleaning products compatible with the equipment.
- No strangulate neither hoses nor nipple.
- Operate the hose with care. The hose can no be exposed to temperatures higher 82°C or bellow -40°C.
- Use hearing protections for equipment use.
- No move or lift the equipment with pressure.
- Bear in mind all the local procedure of safety.



## I INJECTION DANGER

- High-pressure fluid from gun, hose leaks, or ruptured components can cause severe injury.
- The fluid injection may look like a cut, but it is a severe injury. Get immediate surgical treatment.
- Do not block the leaks with your hand or with any parts of your body, even with protections
- Do not point gun at anyone or at any part of the body because it can cause severe injury.
- Do not put your hand over the spray tip.
- Do not spray without tip guard and trigger guard installed.
- Engage trigger lock when not spraying.
- When you stop spraying because you have to clean or check the equipment you must follow the pressure relief procedure.



## E TOXIC FLUID OR FUMES HAZARD

- Toxic fluids or fumes can cause serious injury if splashed in the eyes or on skin, inhaled, or swallowed.
- Know the specific hazards of the fluids you are using.
- Store hazardous fluid in approved containers.
- Use always gloves, mask, glasses and clothes to be protected from the possible hurts.



## FIRE AND EXPLOSION HAZARD

- Poor ventilation, poor grounding or a spark can create a dangerous situation, causing fires or explosions.
- Ground equipment and conductive objects in work area. See grounding instructions.
- If there is static sparking or you feel a shock, stop operation and do not use the equipment again until you identify and correct the cause.
- Use the equipment in well ventilated area.
- Keep the work area free of debris, including solvent, rags and gasoline.
- Do not smoke in the work area
- Keep a fire extinguisher in the work area.



## MOVING PARTS HAZARD

Moving parts can pinch or amputate fingers and other body parts.

- Keep clear of moving parts
- Do not operate equipment without protective guards or covers removed.
- Before checking, moving, or servicing equipment, follow the pressure relief procedure.

The equipment «SUPER MIX» is designed to pulverize two components in different mixing ratios.

Component A: It refers to the resin or the material of largest volume.

Component B: It refers to the catalyst or the material of lower volume.

## **PRESSURE RELIEF PROCEDURE.**

Follow the pressure relief procedure when you stop spraying, cleaning, checking, repairing or transporting the equipment.

To remove the pressure of the equipment, first of all is necessary to close the air valve on unit and turn off the regulator.

Below three ways to remove the pressure are listed:

- I- By means of the gun:
  - Engage trigger lock of the gun, remove the spray tip.
  - Disengage trigger lock of the gun. Hold a metal part of the gun firmly to a metal pail, the metal pail must be grounded. Trigger gun to relieve pressure.
  
- II- By means of the sampling valves:
  - Set the output of the sample keys in a grounded metal pail.
  - Open the sample keys “A“ and “B”.
  - Close the sample keys when the product stops flowing.
  
- III- By means of the purge:
  - When the purges are opened the product returns to the deposit.

## **SHUTDOWN AND CLEANING**

After work or before a material change it is necessary for cleaning.

The process to follow is detailed below.

- 1- Engage trigger lock and follow the Pressure Relief Procedure.

- 2- Remove the spray tip and clean with a compatible solvent and soft brush.
- 3- Turn on the mixer and on the screen press MENU , and then press “Cleaning”. In the submenu “Cleaning” there are two possibilities of cleanliness: the pump “A”, or the pump “B” .
- 4- Open the shutoff valve of the pump to cleaning and put the suction tube in a container with compatible solvent.
- 5- Disengage trigger lock of the gun safety and hold a metal part of the gun firmly to a metal pail, the metal pail must be grounded
- 6- Choose one of the two options possible of the “Cleaning”. Once select our option, the machine will start passing solvent for the pump. If the button “STOP” is not touched, the machine will carry out 20 cycles and later it will stop. We can repeat this operation of cleanliness if it is necessary.
- 7- Engage trigger lock and follow the Pressure Relief Procedure.
- 8- Open the fluid drain valve. Remove the fluid filter and the gun filter and clean them with solvent.
- 9- Flush the sprayer at the end of each work day and fill it with solvent to help prevent pump corrosion.

## **SPRAY TIPS**

When a tips is the wrong size or becomes the wrong size through wear, the spray pattern worsens, coverage decreases, you have less control over the desired rate of coverage and it takes longer to finish the job.

In the worst case, the pump supplying the tip can be damaged, because most architectural coating are abrasive, tip wear can happened quite quickly. Notice as wear increases the orifice size, it decreases the fan width greatly affects coverage rates.

If tip shows excessive wear, replace it to maximize productivity and save paint.

## ALARMS

ALARM	PROBLEM	CAUSE
Alarm: Sensor "A".	No electrical signal from sensor "A".	Loose cable. Failed sensor "A" cable.
Alarm: Sensor "B".	No electrical signal from sensor "B".	Loose cable. Failed sensor "B" cable.
Low Battery.	The automaton's battery is about to end.	Change battery.
Not defined screw.	No data signal between automation and display.	Loose data cable failed data cable.
Display OFF.	No electrical signal between automation and display.	Loose electrical cable, failed electrical cable.

Máximum Ratio 10:1	The máximum ratio permitted is 10:1	A relation bigger than the allowed maximum has been introduced. Presss Intro.
--------------------	-------------------------------------	---

## TROUBLESHOOTING GUIDE

PROBLEM	PROBABLE CAUSE	SOLUTION
The display does not turn on.	The power supply is not connected to the automation.	Check the connections of the automation. Check the electrical diagram, page:10.
	The display is not connected to the automation's power supply.	Check the electrical connections.
	Failed display.	Change display.
The pump does not work.	The air pressure at the pump is too low.	Increase air pressure.
	The air hoses are blocked.	Check the air hoses, they can be twisted.
	The electronic valve does not work.	Check there is 24Vdc on the solenoid. Failed electronic valve.
	The metering valves are not opening.	Check the electronic valve.

PROBLEM	PROBABLE CAUSE	SOLUTION
The volume of the pump test is not correct.	The air pressure at the pump is too low.	Increase pressure.
	The sensor does not work correctly.	Check the sensor's position. Adjust the sensor. Change the sensor.
	The pump cavitations is excessive.	Air in the hoses caused for connectors loose.
The paint is not dry consistently.	The mixing ratio is not well.	Check that the mixing ratio has been entered correctly and that the mixing ratio has been entered by volume.
	The material does not mix correctly.	Make sure the mixer is clean.
	The pump does not work properly.	Observe that the pump is fed correctly.
Poor spray jet	Fluid pressure too low.	Increase pressure pump.
	Dirty or wrong tip.	Pressure relief. Clear or change the tip.
	Clogged fluid filter.	Clear the fluid filter.
	The mixer or hose can be obstructed.	Clear or change the mixer or the hoses which can be obstructed.
The machine works erratically.	The filters can be obstructed.	Clear or change the filters.
	The air supply hose has a smaller diameter section than required.	Change the hoses by others which have a bigger section.
	The air compressor fails to provide sufficient air.	Use a compressor with more capacity.
Safety valve of air supply is opened.	Main air regulator allows the passage of too much air.	Turn down the air pressure.
The machine does not start when you press the start switch.	Failed the start switch or the connection set.	Check the start switch continuity. The switch must be normally open. Check the electrical diagram, page:13.
	Failed the emergency stop.	Check the start switch continuity. The switch must be normally open. Check the electrical diagram, page:13.
	Failed automaton.	Replace automaton.
Leaking in fluid valves.	Gaskets in poor condition.	Change gaskets.
Flow of product too low.	Inadequate air supply.	Use a compressor with more air flow.
	Inadequate air pressure in the pump.	Increase the pressure.
	Fluid filters are obstructed.	Clear the fluid filters.
	Spray tip too small.	Pressure relief. Change the spray tip by one bigger.
	The mixer or the hoses are obstructed.	Clear or change the units which are obstructed.

## PROCEDURE LIFTING OF UNIT

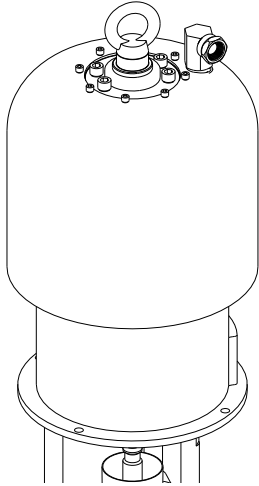

(fig. 1)



### WARNING

HOLD OR IMMOBILIZE THE TROLLEY.

USE A CHAIN, HOOKING AN END TO EACH OF THE MACHINE AIR MOTOR RINGS. HOOK THE CENTRAL LINK OF THE CHAIN ON A CRANE. CAREFULLY LIFT THE MACHINE AND MAKE SURE THE MACHINE IS WELL-BALANCED.

## STARTING

Before starting of the machine must be checked:

- The hose, which will be used to the output of the product, must be high pressure.
- Engage trigger lock of the gun.
- Check the hoses, through which the material will flow, are in good condition.
- Check the hoses, through which the air pressure will flow, are in good condition.
- Fill the material deposits “A” and “B”.
- Connect the machine to air supply and power supply.
- Check the air pressure of the whole system.

## TO FEED THE PUMPS



(Screen 1)

Home screen.

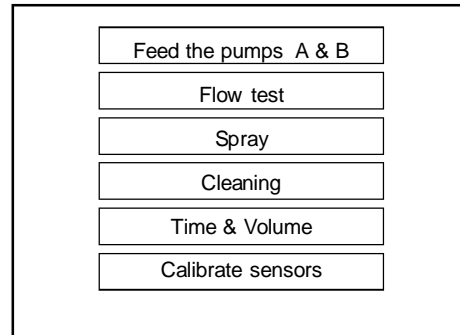

(Screen2)

Pressing “Menu” in the screen 1” is reached the menu screen.

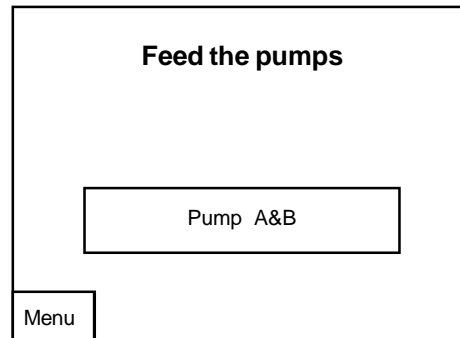

(Screen 3)

Pressing “Feed the pumps A and B”.

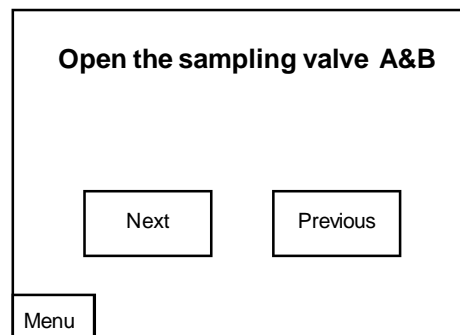

(Screen 4)

When the valves are opened we have to press “Next” to continue. If it is pressed “Previous” Returns to the screen 3.

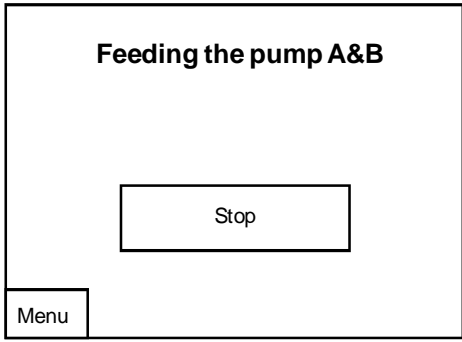

(Screen 5)

The pumps A&B are fed, the pumps will stop automatically after 40 cycles or the operator can stop the pumps if he press “Stop”.

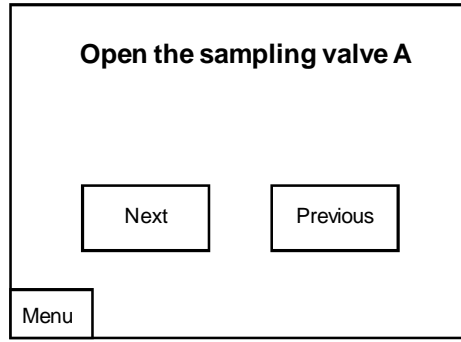

(Screen 8)

If we choose the “Pump A” we have to open the sampling valve and press “Next” to continue.

If it is pressed “Previous” returns to the screen 7.

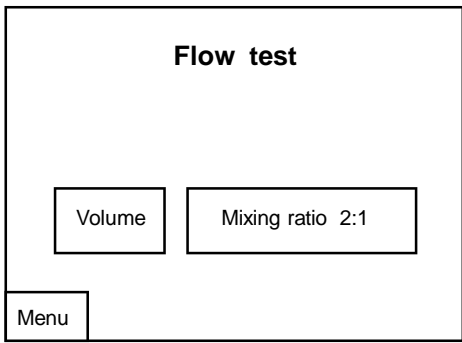

(Screen 6)

If we press “Flow test” and we can get this screen where we have two possibilities to check rules to measure well.

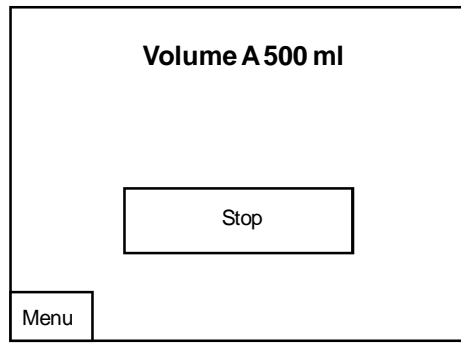

(Screen 9)

The pump A gives 500 ml in the test tube. If there is some mistake and the pump does not stop automatically, the operator can stop the pump if he press stop.

If the option “Pump B” is pressed in the screen 7 we have the same steps for the pump B.

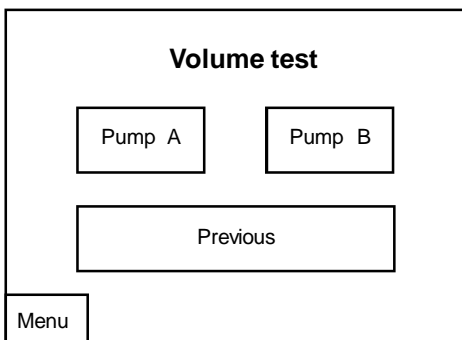

(Screen 7)

Pressing “Volume test” and we can get this screen where we can choose the pump that we want to test. Press “Previous” and we will come back to Screen 6.

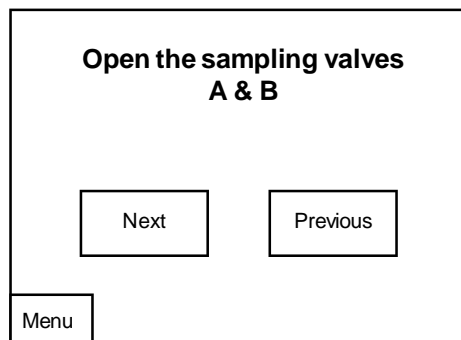

(Screen 10)

Press “Mixing ratio 2:1” in the screen 6. Open the sampling valves A&B and press “Next” to continue. If it is pressed “Previous” Returns to the screen 6



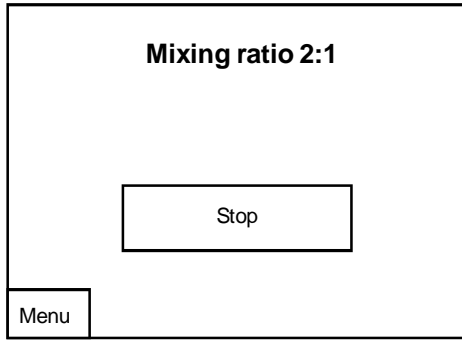

(Screen 11)

The pump A gives double that pump B. If there is any mis take and the pumps do not stop automatically, the operator can stop the pumps pressing “Stop” .

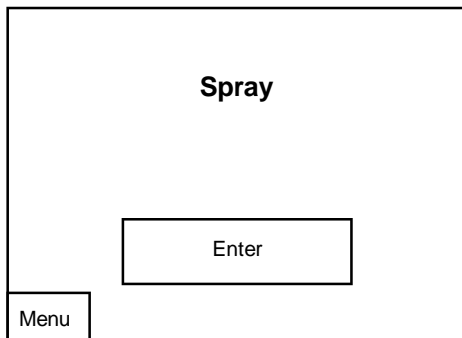

(Screen 12)

If we press “Spray” in the screen 2 the program will send us to this screen where we will have to press “Enter” to continue.

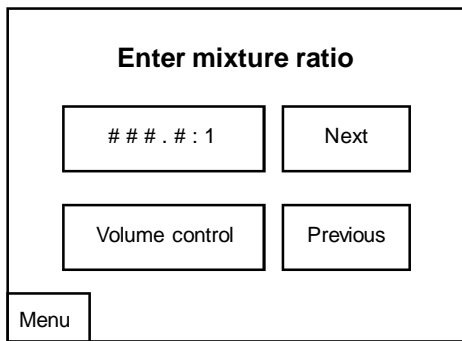

(Screen 13)

Press on the box “###.#:1” and a numeric key pad will appear. Type the mixture ratio and press “Enter” .

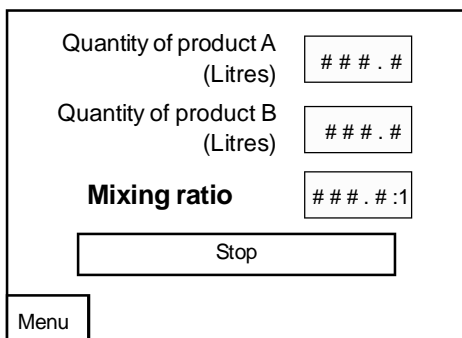

(Screen 14)

Press “Next” in the screen 13. We can see the mixing ratio and the litres that are being used in the application. Press “Stop” and the machine will stop.

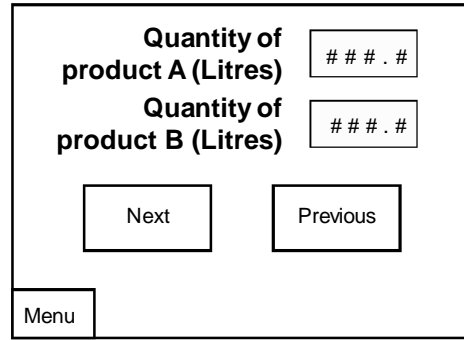

(Screen 15)

Press “Volume control” in the screen 13. We can enter the volume that we have of each product (maximum 999.9 litres).

If it is pressed “Next” and we can get this screen 16 and “Previous” Returns to the screen 13.

Note: To write the volume we have to press on the number that has a marquee and a numeric keypad will appear.



(Screen 16)

Press “Next” in the screen 13. We can see the remaining liters in each container. The machine will stop before the products end. And then will come the screen 30.

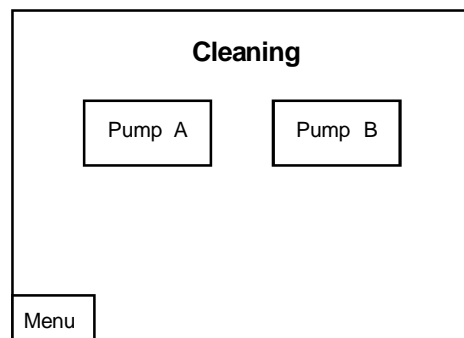

(Screen 17)

Press “Cleaning” in the screen menu. We can choose the pump that will be cleaned.

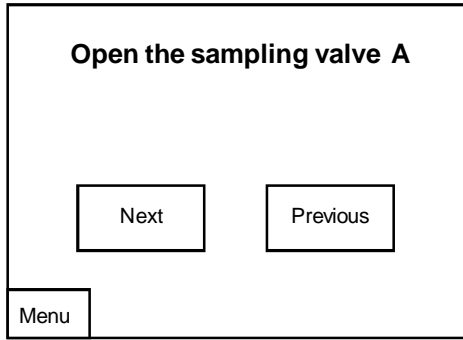

(Screen 18)

If we choose the “Pump A” we have to open the sampling valve and press “Next” to continue.

If it is pressed “Previous” Returns to the screen 17.

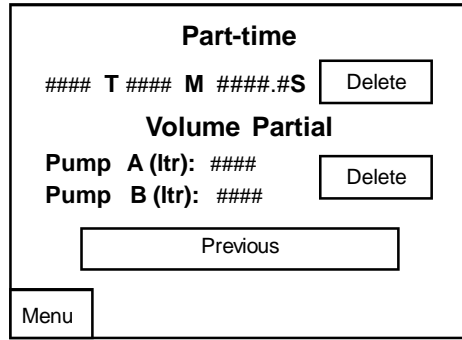

(Screen 21)

If it is pressed:

- “Delete” We can delete value of part-time and partial volume.

-“Previous” Returns to the screen 20.

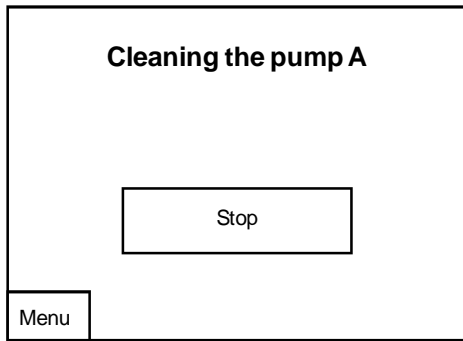

(Screen19)

The pump A is cleaned, the pump will stop automatically after 20 cycles or the operator can stop the pump if he press “Stop”.

If the option “Pump B” is pressed in the screen 17 we have the same steps for the pump B.

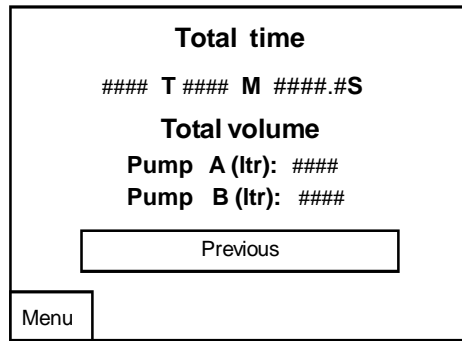

(Screen 22)

We can see the time and the litres used since the machine has been manufactured.

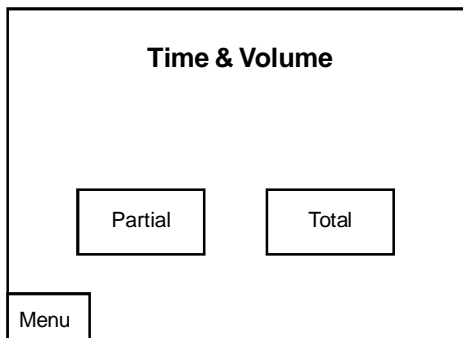

(Screen 20)

Press “Time and Volume” in the screen 2. If it is pressed “Partial” We can see the time and the litres used on an application. If it is pressed “Total” We can see the time and the litres used since the machine has been

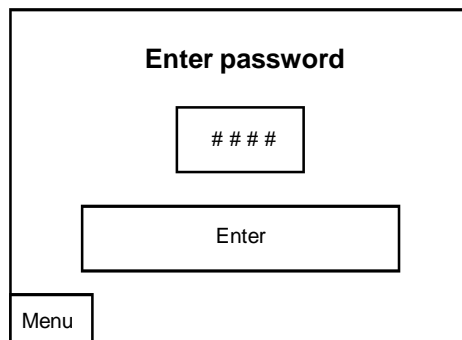

(Screen 23)

“Calibrate Sensors” in the screen 25.

First introduce password (4321) and then click “Enter”.

You only have to use this option when you think that sensor is working wrong.



**If we go into this submenu and we don't follow the steps correctly, the machine will not work properly.**

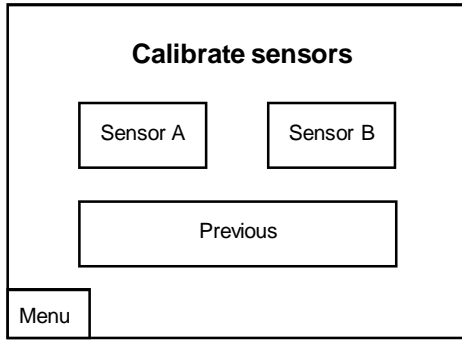

(Screen24)

We have to choose the sensor that we want to calibrate. Press "Previous" and the machine will stop and come back to screen menu.

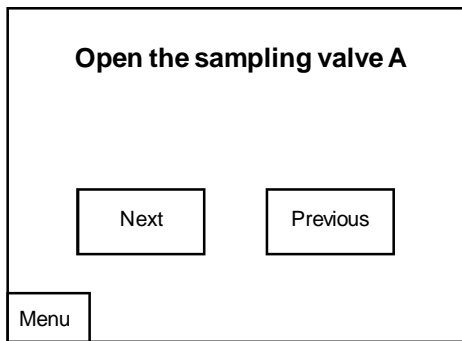

(Screen 25)

If we choose the "Pump A" we have to open the sampling valve A and press "Next" to continue.

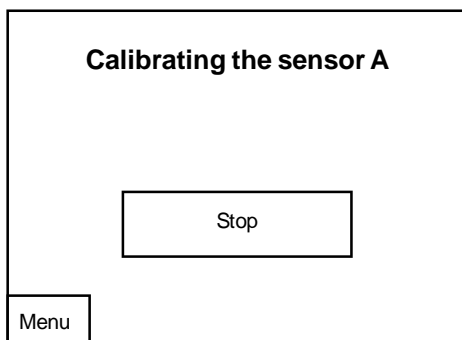

(Screen 26)

The pump A has to move during 6 to 8 cycles and then the operator must press . The pump A will stop and the Screen 23 will appear.

If the option "Sensor B" is pressed in the screen 24 we have the same steps for the Sensor B.

## ERROR SCREENS

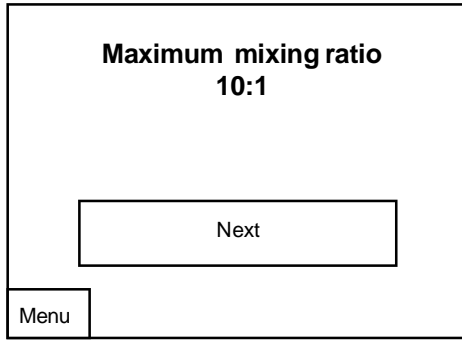

(Screen 27)

The maximum mixing ratio is 10:1, if we try to enter more this screen will appear.

Press “Previous” and the screen 13 will appear.

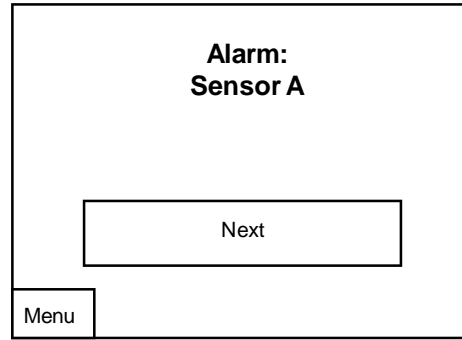

(Screen30)

If this screen appears the sensor A or its electric cable must be checked.

We have to repair the sensor before use the machine again.

NOTE: If replace or move the sensors, please calibrate them again.

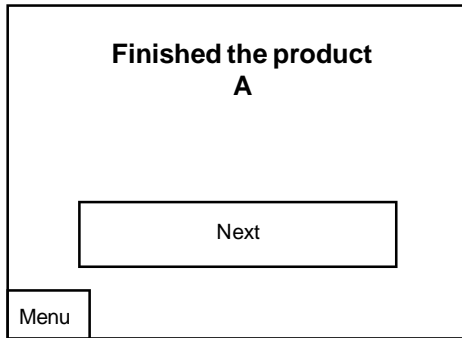

(Screen 28)

Depending on the volume that has been introduced in screen 15, machine will stop before the end of the product.

Press “Next” to return to the screen 15.

Note: There is another screen for the product B.

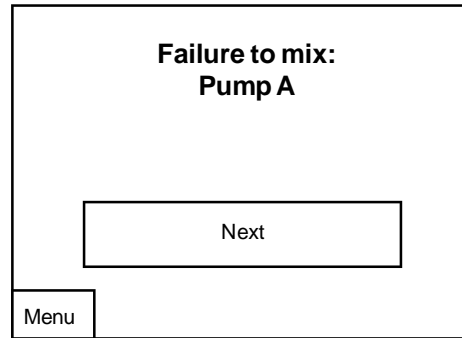

(Screen 31)

One of the pumps is leaking and the mixing is being wrong. Check the pump and repair it.

Once the pump is ok, press “Next”.

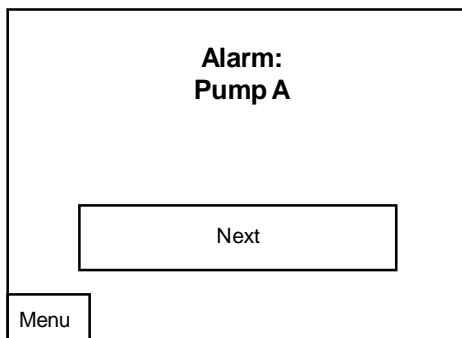

(Screen 29)

If the product A is finished or the pump A has a problem this screen will appear.

Press “Previous” and the screen will disappear.

Note: There is another screen for the Pump B.

# ELECTRONIC DIAGRAM

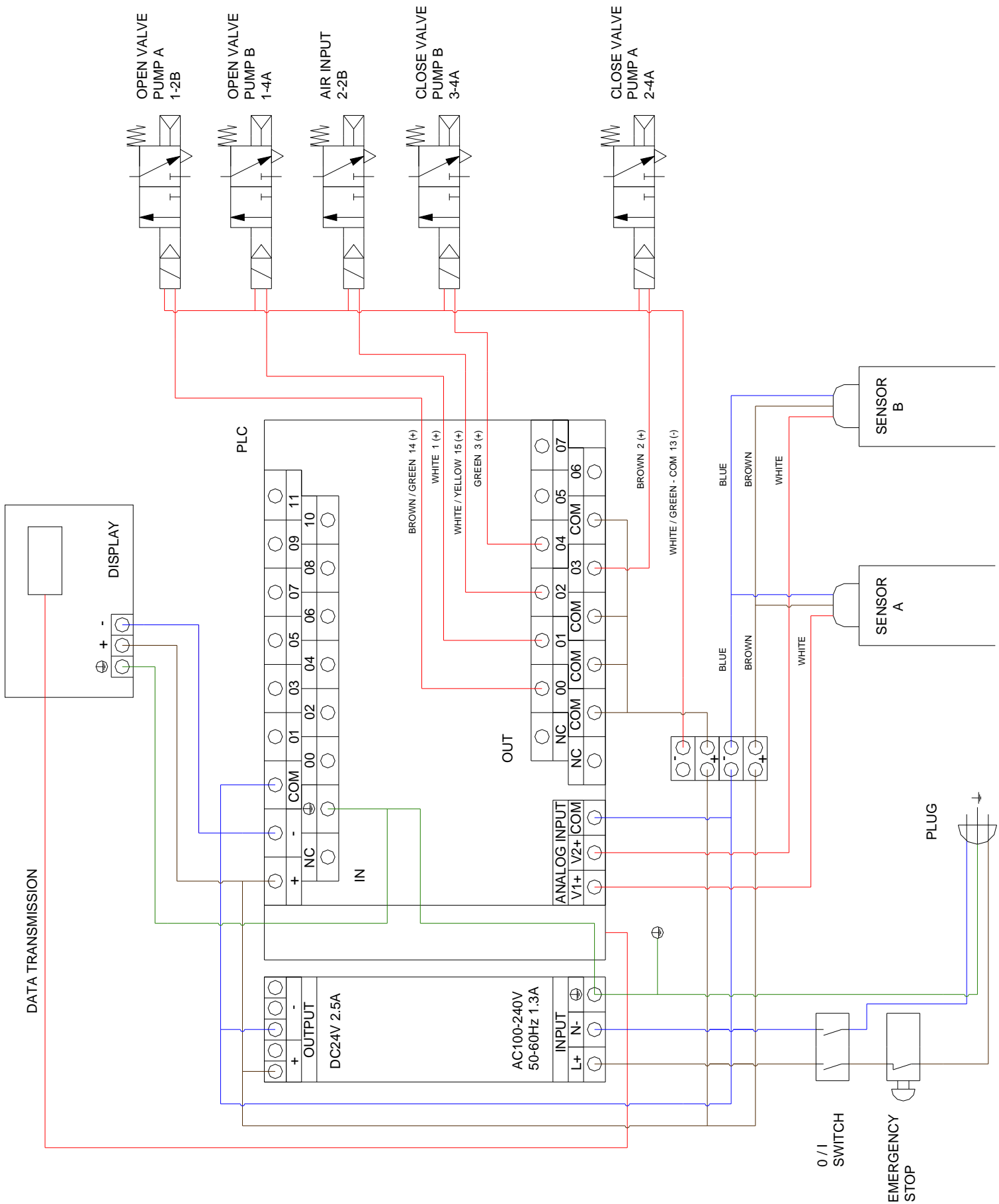

(fig. 2)

# EQUIPMENT PARTS

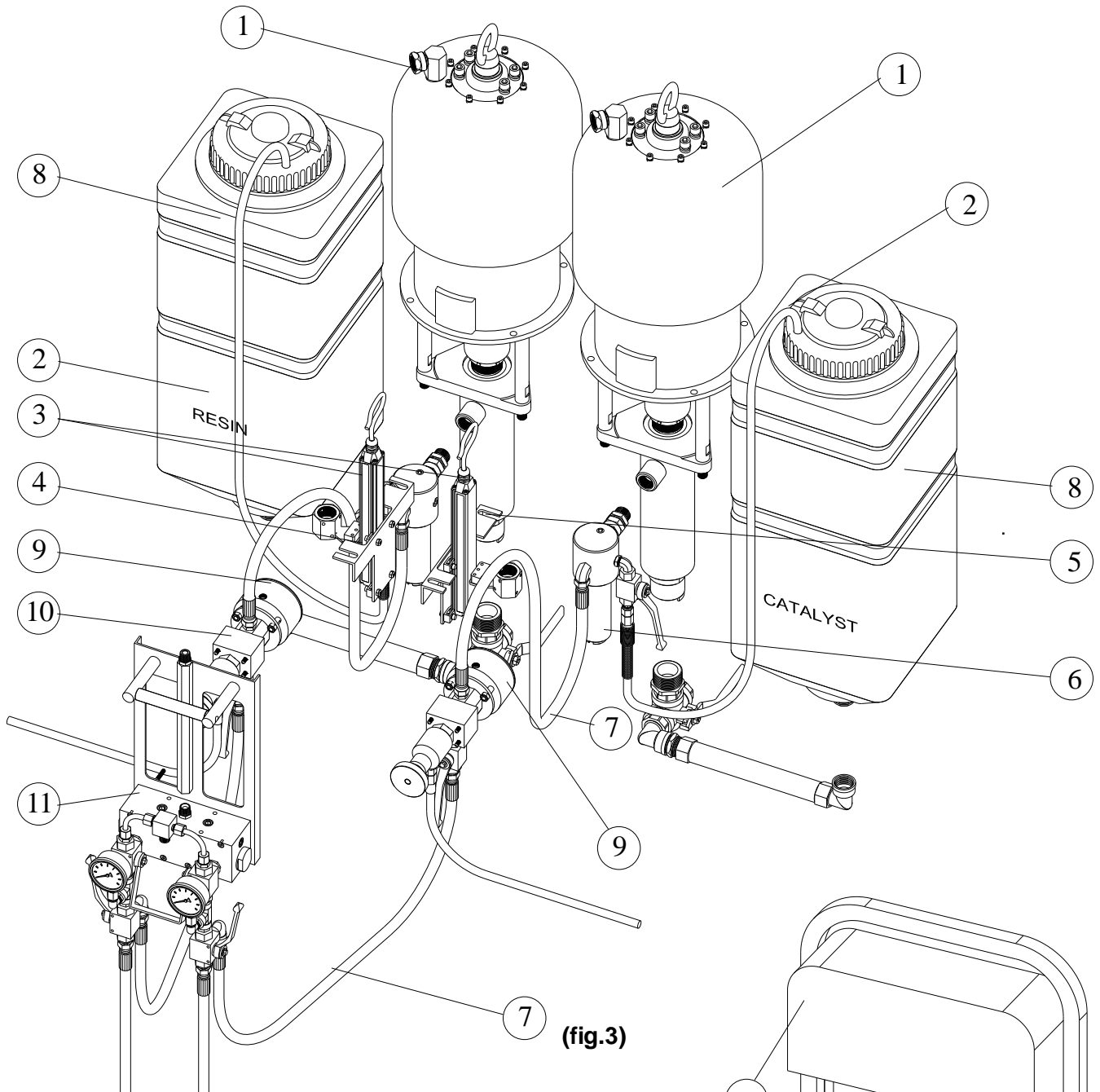

(fig.3)

N°	REF.	DESCRIPTION	Q
1	HD-63	PUMP	2
2	SM.520.00	PURGE	2
3	CNB.012	SENSOR	2
4	SM.100.01	SUPPORT	1
5	SM.100.02	SUPPORT	1
6	G.500.00X	HP FILTER	2
7	SM.121.00	HOSE	4
8	SM.200.00	FLUID RESERVOIR	2
9	SM.800.00	VALVE	2
10	SM.120.00	SAMPLING VALVE	2
11	M.500.00	FLUID MANIFOLD	1
12	SM.400.00	ELECTRONIC BOX	1
13	SM.300.00	TROLEY	1
14	TEL 46X	CLEANING PUMP	1

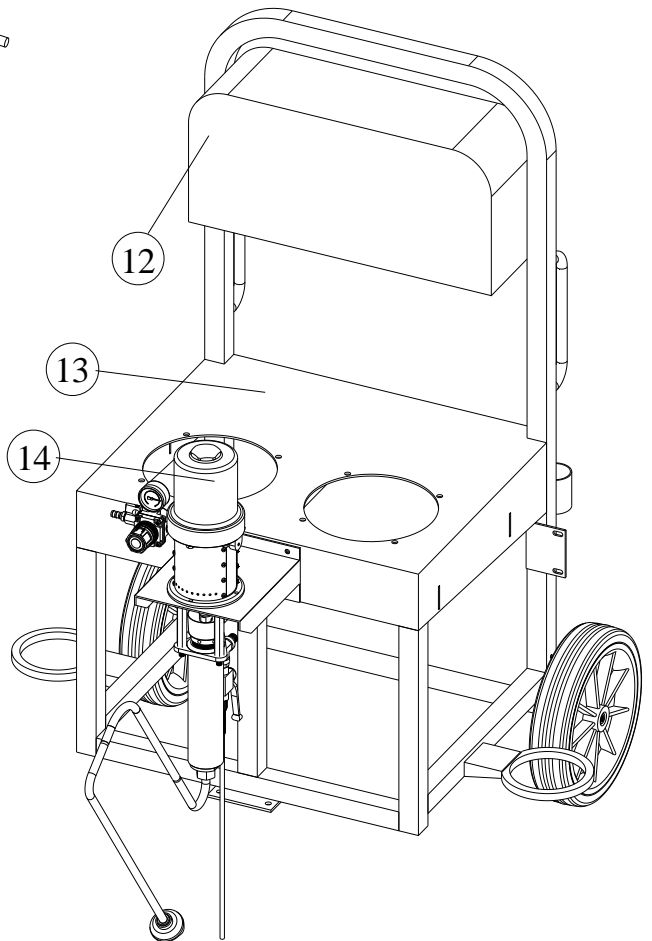

# PNEUMATIC CONNECTIONS

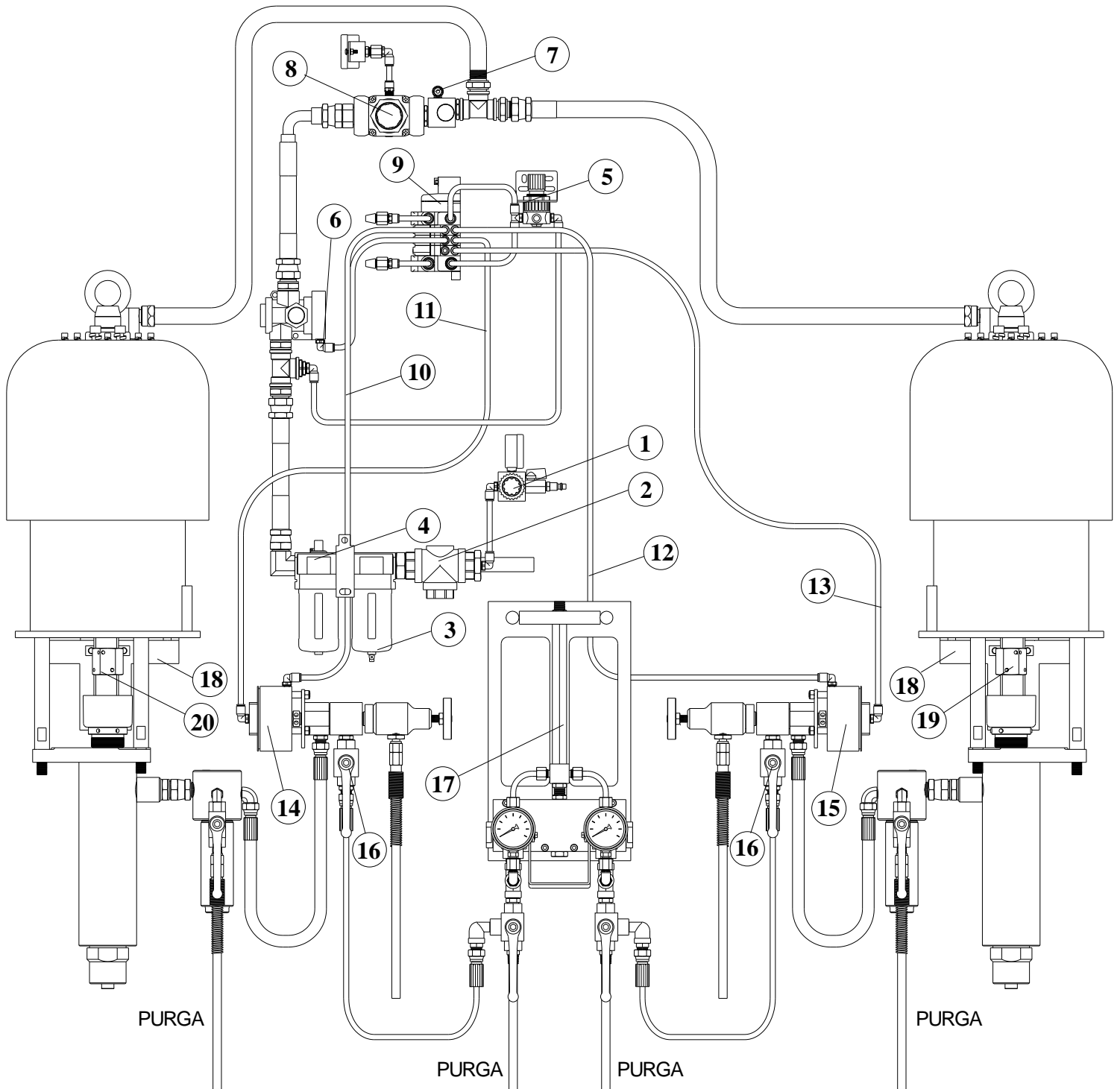

(fig. 4)

- |                                   |                                    |
|-----------------------------------|------------------------------------|
| 1.- Air input cleaning pump.      | 11.- Electronic valve "A" , close. |
| 2.- Air input system .            | 12.- Electronic valve "B" , open.  |
| 3.- Air Filter.                   | 13.- Electronic valve "B" , close. |
| 4.- Auto drain.                   | 14.- Metering valve "B"            |
| 5.- Regulator.                    | 15.- Metering valve "A"            |
| 6.- Valve close.                  | 16.- Shutoff valve.                |
| 7.- Safety valve.                 | 17.- Fluid manifold.               |
| 8.- Main regulator.               | 18.- Guide.                        |
| 9.- Electronic valve air input.   | 19.- Sensor de la resin.           |
| 10.- Electronic valve "A" , open. | 20.- Sensor del catalyst.          |

# METERING VALVE SM.120.00

## Disassembly

First follow the pressure relief procedure.

Remove the hose, number 30, which joins the HP filter (G.500.00X) with the valve (SM.800.00) and the shutoff valve, number 8, with the fluid manifold (M.500.00).

Remove the air hose, number 29.

Remove the four screws (n°5) and the four nuts (n°10) which hold the metering valve with the trolley.

Change all joints that are damaged.

Clear all the parts before reassembling the metering valve.

**NOTE:** Whether to change the needle, number 13, is recommended to change the seat assembly, number 12.

**NOTE:** Apply sealant to threads.

N°	REF.	DESCRIPTION	Q
1	104.251.00	SAMPLING VALVE	1
2	SM.120.02	NIPPLE	1
3	SM.123.00	HOSE	1
4	SM.120.01	HOUSING	1
5	CTB.016	SCREW	4
6	G.500.04X	NIPPLE	3
7	CNC.018	SUTOFF VALVE	1
8	SM.121.00	HOSE	1
9	CAR.021	WASHER	4
10	CTU.105	NUT	5
11	SM.800.01	HOUSING	1
12	SM.800.12	NEEDLE	1
13	SM.800.08	MALE GLAND	1
14	SM.800.11	PACKING	4
15	SM.800.09	FEMALE GLAND	1

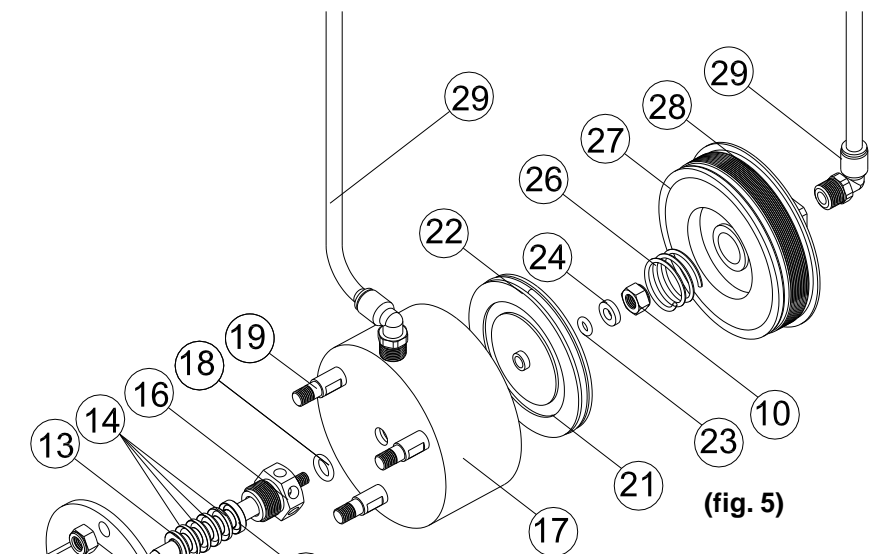
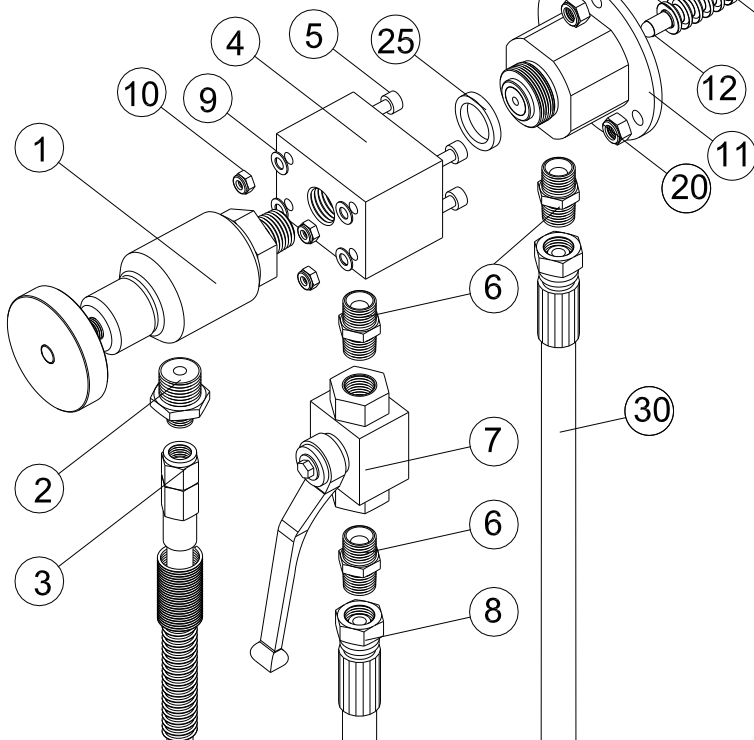

N°	REF.	DESCRIPTION	Q
16	SM.800.02	PACKING NUT	1
17	SM.800.04	HOUSING	1
18	CJT.061	O-RING	1
19	SM.800.07	SPACER	3
20	CTU.106	NUT	3
21	SM.800.05	PISTON	1
22	CJT.066	O-RING	1
23	CJT.013	O-RING	1
24	SM.800.06	WASHER	1
25	SM.800.13	JOINT	1
26	A.410.16	SPRING	1
27	SM.800.03	JOINT	1
28	SM.800.10	PLUG	1
29	SM.122.00	AIR HOSE	2
30	SM.121.00	HOSE	1



# FLUID MANIFOLD M.500.00

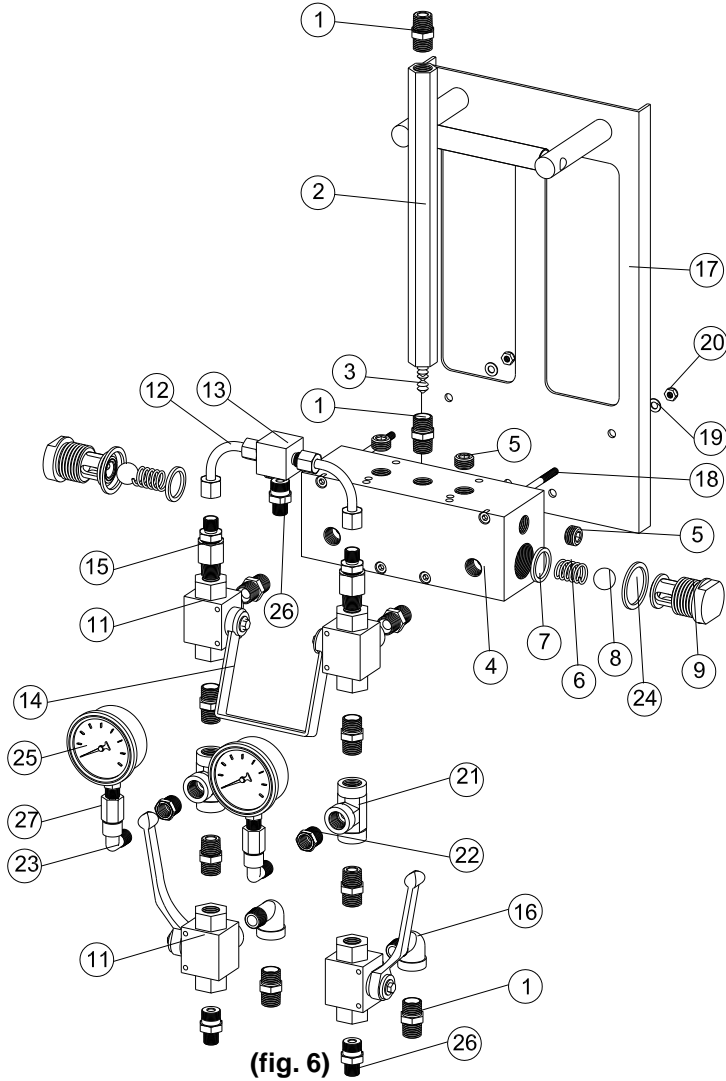

(fig. 6)

N°	REF.	DESCRIPTION	Q
1	G.500.04X	NIPPLE	10
2	M.410.01	MIXER TUBE	1
3	CNE.004	STATIC MIXER	1
4	SM.110.01	HOUSING	1
5	CTF.003	PLUG	6
6	K.300.04	SPRING	2
7	SM.110.02	JOINT	2
8	CBO.109	BALL	2
9	SM.111.00	PLUG	2
11	CNC.017	VALVE	4
12	M.510.00	TUBE	2
13	M.500.03	BODY	1
14	M.400.05	HANDLE	1
15	SM.112.00	NON RETURN VALVE	2
16	CNA.036	ELBOW	2
17	M.520.00	SUPORT	1
18	CTB.041	SCREW	4
19	CAR.021	WASHER	4
20	CTU.105	NUT	4
21	CNA.128	NIPPLE T	2
22	CNA.052	NIPPLE	2
23	CNA.037	NIPPLE	2
24	SM.110.04	JOINT	2
25	CNB.007	GAUGE	2
26	16.000.07X	NIPPLE	3
27	CNB.015	CONNECTOR	2

Unscrew the plug, number 9.

Substitute the o-rings, number 7 and number 24, the balls, number 8, and the springs, number 6.

Reassemble all the parts, applying sealant to the threads of the plug.

## SENSOR

### CHANGE OF SENSOR.

First follow the pressure relief procedure.

Open the user interface cover.

Disconnect the wires of the sensor from the analogy input unit.

Remove the sensor from the support (number 3, figure 3)

Assemble the new sensor on the support and connect the wires in the analogy input unit. Consult the electronic diagram (figure 2).

The distance between the magnet and the sensor should be between 4 and 5 mm.

### RECALIBRATE SENSOR

Enter the submenu of the sensor which must be recalibrated, open the sampling valve, insert the hose into a container and press "Enter".

When the machine has made 5-6 cycles the button "Stop" can be pressed.

To verify that the sensor is properly calibrated first feed the pump and then do the flow test.

**NOTE:** Just should enter this submenu when a sensor has been changed or when the flow test's results are wrong.

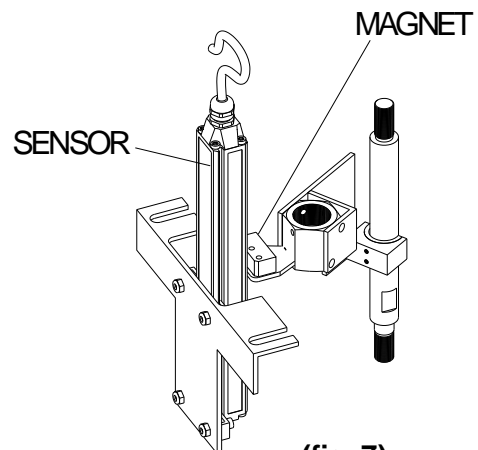

(fig. 7)

### SOFTWARE:

The versions of software are:

- Ration2.0 (Display)
- Ratio 2.1 (Automaton)

# AIR MOTOR

The working pressure should be between 2 and 5.5 bars.

N°	REF.	DESCRIPTION	Q
1	A.421.00	PISTON	1
2	CJT.018	O-RING	1
3	A.422.00	SHAFT	1
4	A.420.01	CONNECTOR	1
5	CAB.008	PACKING	1
6	A.430.03	JOINT	2
7	A.400.03	JOINT	1
8	CJT.019	O-RING	1
9	CB2.009	SLEEVE	1
10	CB2.010	SLEEVE	1
11	A.430.01	MOTOR BODY	1
12	A.430.02	WASHER	1
13	CTT.008	SCREW	12
14	CTU.141	EYRE	1
15	CTT.006	SCREW	8
16	CTT.007	SPRING WASHER	8
17	A.440.00	AIR INLET RACOR	1
18	A.400.01	HOUSING	1
19	CTT.005	SPRING WASHER	4
20	CTT.004	SCREW	4
21	A.410.08	SUPPORT	1
22	CPA.213	PIN	2
23	A.410.02	JOINT	2
24	A.410.03	SEAT	2
25	A.410.18	NUT	1
26	CAR.053	SPRING WASHER	1
27	A.410.17	AIR VALVE HOUSING	1
28	A.410.19	HUB	1
29	A.411.03	SLEEVE	1
30	A.411.04	JOINT	1
31	A.411.01	CONNECTOR	1
32	CAB.007	PACKING	1
33	CAR.012	JOINT	1
34	A.410.10	PLUNGER	2
35	A.410.12	SPRING DETENT	2
36	A.410.11	SPRING	2
37	A.410.13	SPRING RETAINER	2
38	A.410.09	ROLLER	2
39	CTT.002	SCREW	8
40	A.400.02	JOINT	1
41	CTT.001	SCREW	4
42	CTT.003	SPRING WASHER	4
43	A.410.04	JOINT	2

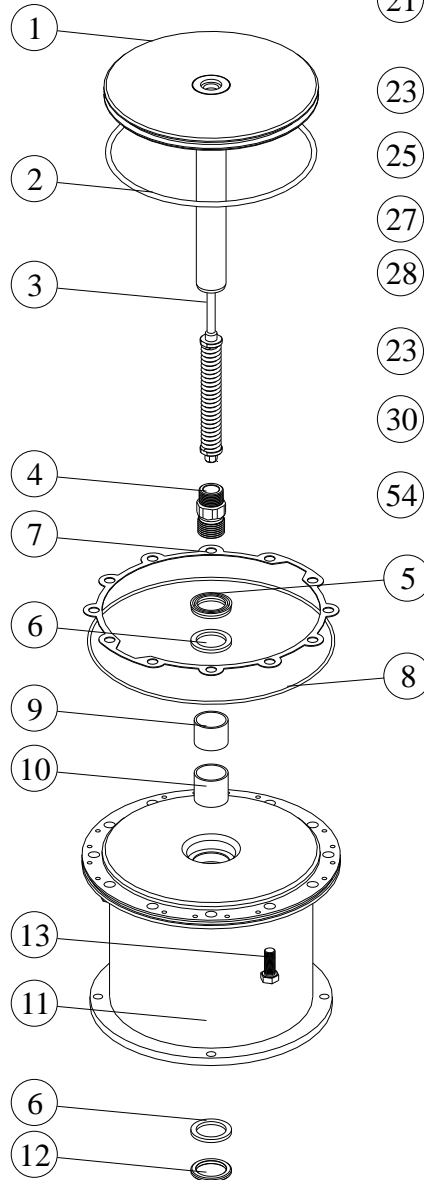

(fig. 8)

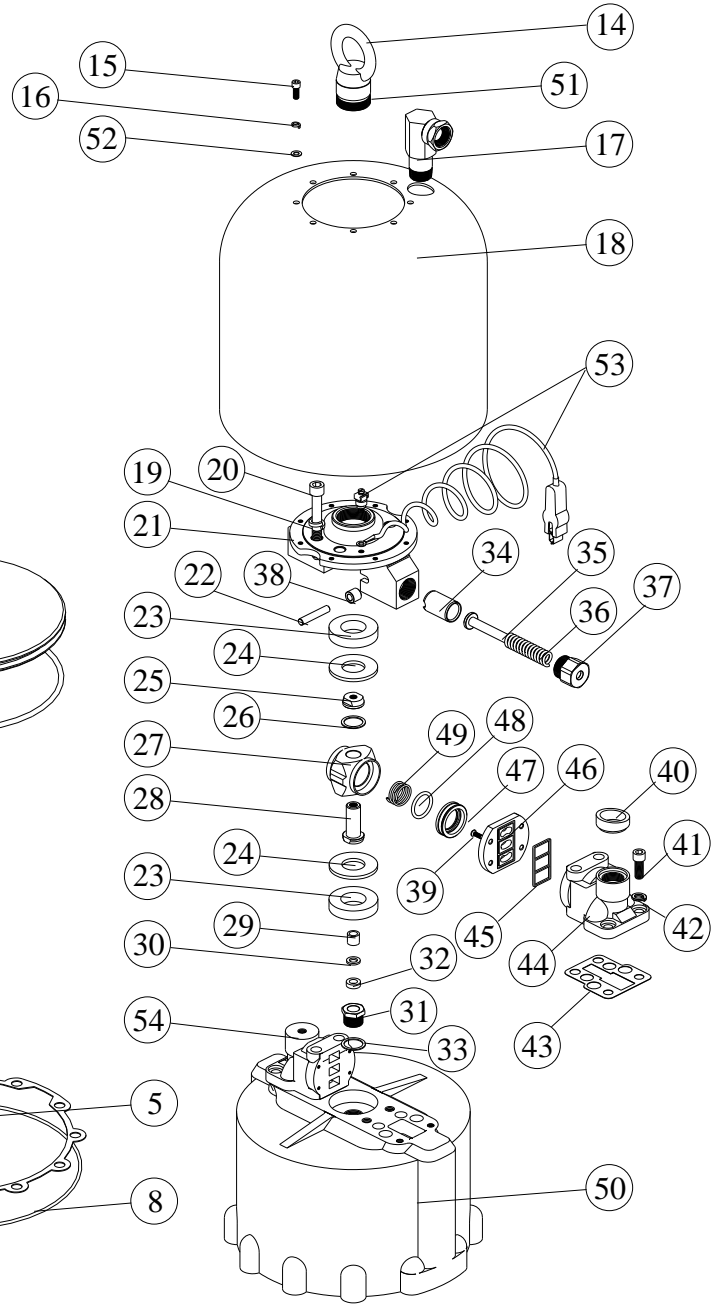

44.\* Valve body threaded

54.\* Valve body without thread

N°	REF.	DESCRIPTION	Q
*44	*A.410.05A	VALVE BODY	1
45	A.410.07	JOINT	2
46	A.410.06	VALVE SEAT	2
47	A.410.15	VALVE	2
48	CJT.001	O-RING	2
49	A.410.16	SPRING	2
50	A.410.01	CYLINDER	1
51	A.410.14	SPRING	1
52	CAR.021	WASHER	8
53	TIE.GR	GROUND	1
*54	*A.410.05B	VALVE BODY	1

# DISPLACEMENT PUMP

Cleaning the machine is absolutely necessary for a proper functioning, as well for a prolonged life.

N°	REF.	DESCRIPTION	Q
1	B.420.00	PACKING NUT	1
*2	B.440.01	FEMALE GLAND	2
*3T	B.440.02T	PACKING	10
*4	B.440.03	MALE GLAND	2
5	B.410.00	HOUSING	1
6	B.400.01	PTFE JOINT	1
7	B.450.00	ROD	1
8	B.400.02	SLEEVE	1
9	CBO.109	BALL	1
10	B.440.04	RETAINER	1
11	B.451.00	PISTON	1
12	CB0.115	BALL	1
13	B.460.03	BALL GUIDE </td <td>1</td>	1
14	B.460.04	PIN	1
15	B.460.02	PTFE JOINT	1
16	B.461.00	INTAKE VALVE	1
17	G.100.02X	COVER	1
18	G.100.20	FILTER	1
19	G.100.04	SPRING	1
20	CTA.901	SCREW	1
21	G.500.03X	SUPPORT	1
22	G.100.07	JOINT	1
23	G.500.01X	BODY	1
24	CNA.032	NIPPLE	1
25	CTF.001	PLUG	1
26	CTF.003	PLUG	2
27	CNA.155	NIPPLE	1
28	CNA.154	NIPPLE	1
29	C.500.01	SPACER	3
30	CTT.009	NUT	3
31	C.410.01	SLEEVE	2
32	SM.510.03	NUT	1
33	CEA.086	MAGNET	1

\* Included in KIT.011T

**NOTE:** Fix parts 7 and 11 with loctite 542 or similar  
(wait 1 hour before start running the unit)

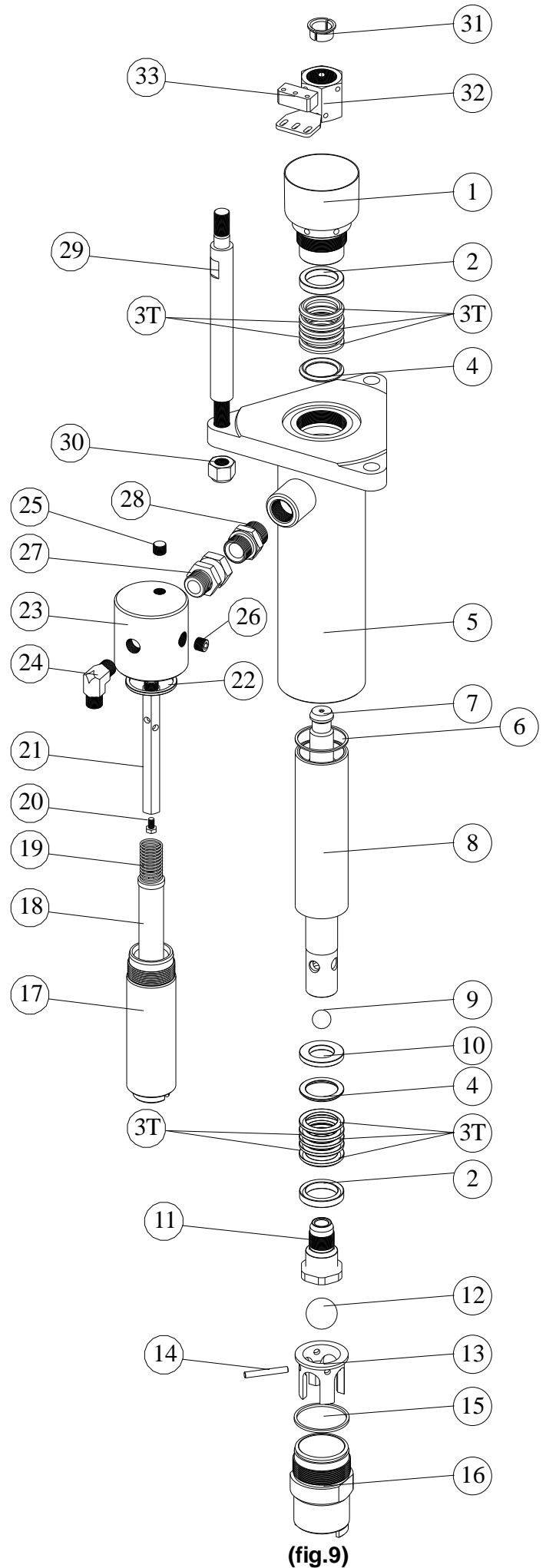

# AIR MOTOR

N°	REF.	DESCRIPTION	Q
1	A.110.02	CAP	1
2	CJT.001	JOINT	1
3	A.210.01	CYLINDER	1
4	A.120.04	ROD	2
5	A.220.07	SUPPORT	1
6	A.120.08	YOKE	1
7	A.221.00	ROD	1
8	CTJ.002	SCREW	2
9	A.240.02	CLIP	2
10	A.240.01	PISTON	1
*11	A.122.00	STEM	2
*12	CJT.005	JOINT	1
13	A.220.11	ROD	1
*14	CJT.007	JOINT	1
15	CB2.015	SLEEVE	1
*16	CJT.006	JOINT	1
17	A.130.02	PLATE	2
18	A.250.01	BASE	1
19	CTA.001	SCREW	6
20	CTC.001	SCREW	16
21	A.120.01	ROCKER	2
22	A.120.02	SPRING	2
23	A.120.03	ROD	2
*24	A.120.05	CLIP	2
25	A.120.06	NUT	4
26	A.150.02	JOINT	1
*27	A.120.10	JOINT	2
*28	A.220.09	JOINT	2
29	CAR.125	RETAINER	1
30	TIE.GR	GROUND	1

\* Included in KIT.054

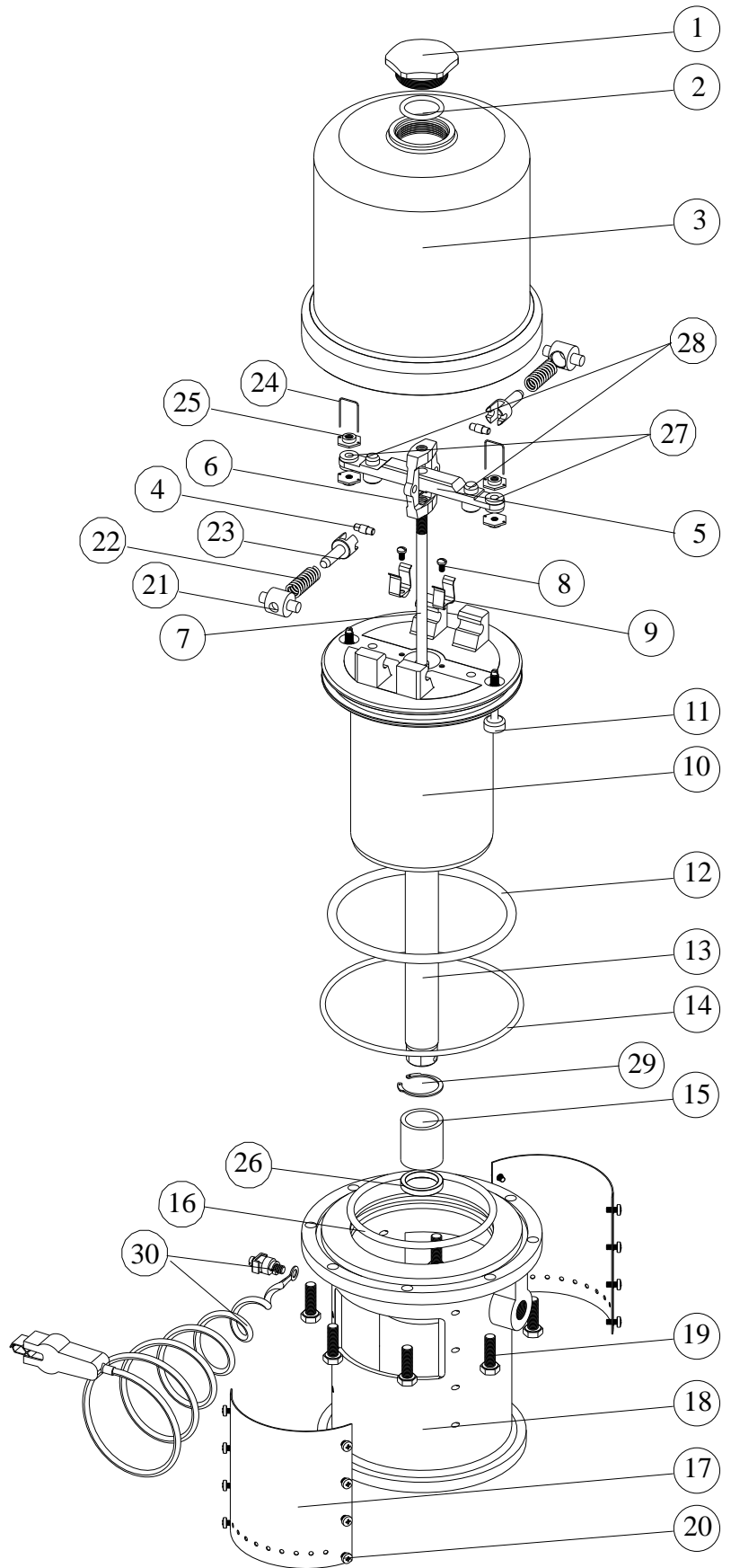

(fig.10)

# DISPLACEMENT CLEANING PUMP

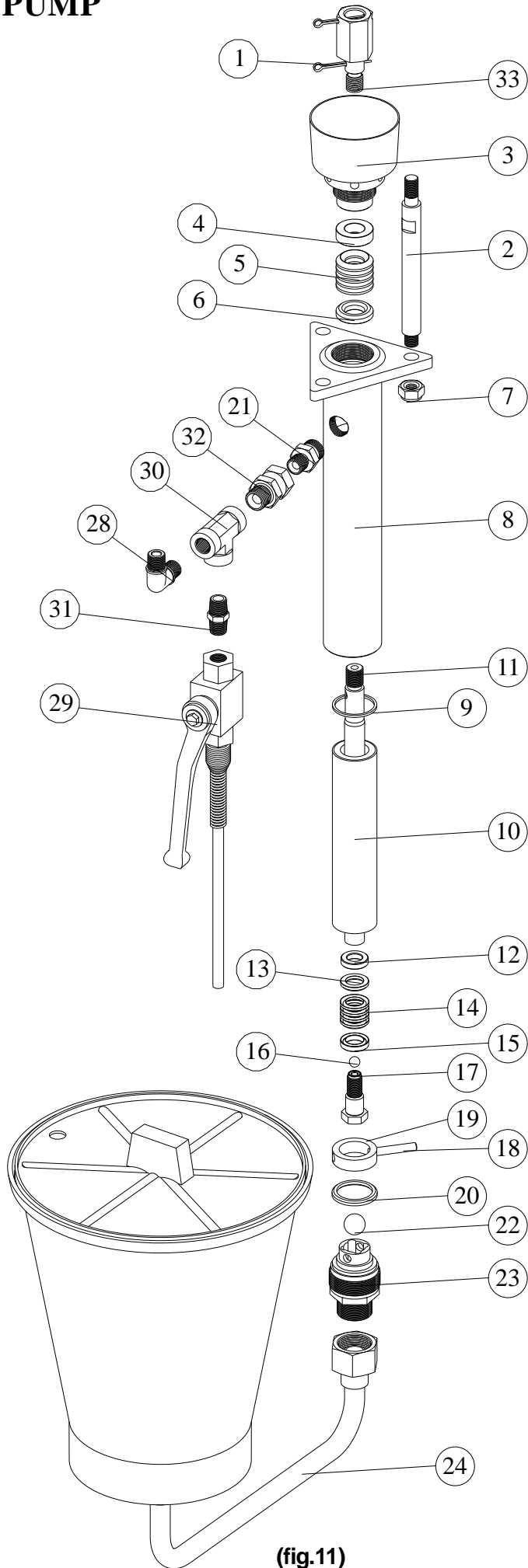

(fig.11)

N°	REF.	DESCRIPTION	Q
1	CPA.101	PIN	2
2	C.201.01	TIE	3
3	B.120.00	PACKING NUT	1
*4	B.131.01X	FEMALE GLAND	1
*5	B.131.02	PACKING	5
*6	B.131.03X	MALE GLAND	1
7	CTU.101	NUT	3
8	B.110.00	HOUSING	1
9	B.100.01	JOINT	1
10	B.100.12	SLEEVE	1
11	B.100.13	ROD	1
*12	B.141.01X	WASHER	1
*13	B.141.02X	MALE GLAND	1
*14	B.141.03	PACKING	4
*15	B.141.04X	FEMALE GLAND	1
16	CBO.101	BALL	1
17	B.151.00	PISTON	1
18	B.100.05	PIN	1
19	B.100.04X	RETAINER	1
20	B.100.06	JOINT	1
21	16.000.07X	NIPPLE	1
22	CBO.104	BALL	1
23	B.160.00X	VALVE	1
24	D.200.00	5 lit PAIL	1
28	CNA.063	NIPPLE	1
29	G.110.00	PURGE	1
30	CNA.115	NIPPLE	1
31	CNA.055	NIPPLE	1
32	CNA.116	NIPPLE	1
33	C.201.02	UNION ROD	1

\* Included in KIT.002X

**NOTE:** Fix parts 11 and 17 with loctite 542 or similar (wait 1 hour before start running the unit).

## AIRLESS GUN Mod. J.600

A good implementation is a good combination between the size of the spray tip, the filter and the air pressure. Together these three elements can be obtained a significant control to paint a difficult piece or to achieve a high performance to work in series.

In the case of the guns, as in the pump, the cleanness is very important for the smooth running of the gun.

Whenever is possible we must avoid spraying abrasive products because they shorten the life of the closing of the gun.

With the products of two components is important know the life of the mixture, because the mixture can be catalysed at the internal parts of the gun.

To clean should be used in a cleaning solvent and no the solvent used to lower the mix.

The airless gun, J.600, has a sophisticated system of opening-closing for the passage of material into the spray tip. The closing takes place between the needle's ball and the seat of the diffuser.

The material of the ball and of the seat is tungsten carbide.

The filter is inside the handle.

The nipple, which is the connection between the hose and the gun, is revolving. For facilitate the use of the gun.

Whenever the gun is not used is necessary to engage trigger lock.

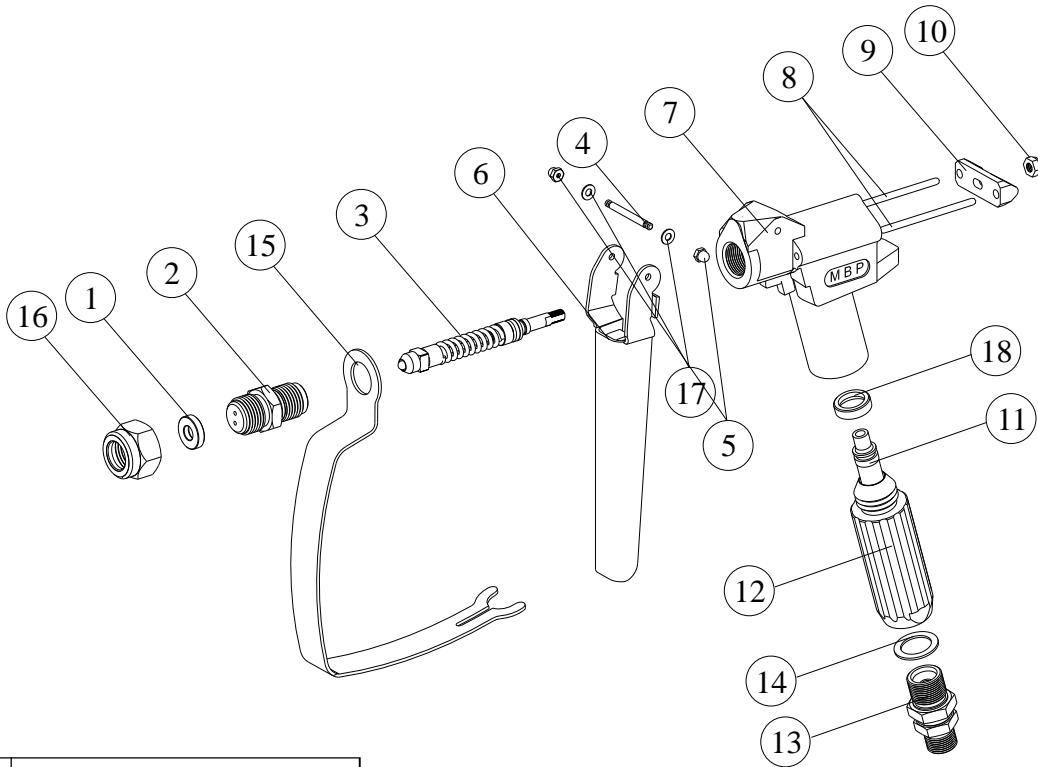

(fig.12)

N°	REF.	DESCRIPTION
1	J.200.10	JOINT
2	J.210.00	NEEDLE SEAT
3	J.620.00	NEEDLE COMPLETE
4	J.501.500.15	TRIGGER PIN
5	C.TU0.11	NUT
6	J.230.00	TRIGGER
7	J.200.01	GUN BODY
8	J.200.05	PIN
9	J.250.00	CAP
10	C.TU1.03	NUT
11	J.260.01	FILTER
12	J.600.03	HANDLE

N°	REF.	DESCRIPTION
13	J.240.00	NIPPLE
14	J.200.04	JOINT
15	J.200.02	GUARD
16	J.200.09	NUT
17	J.200.07	WASHER
18	J.200.08	SEAT

## CONVERSION OF WEIGHT RATIOS TO VOLUMETRIC RATIOS

Some manufacturers suggest the mixture in percentage or ration volumetric and other in proportion or ration of weight.

As the sensors measure volume, the ratio is required in volume.

### Conversion example:

- 5 parts in weight of the component A or 5gr of component A
- 1 parts in weight of the component B or 1gr of component B
- 5:1 according to the weight ratio

The density or volume of the components must be known in advance, we assume that the volume is known.

First calculate the density:

$$d_A = \frac{\text{Mass}_A}{\text{Volumen}_A} = \frac{0.15 \text{ gr}}{0.10 \text{ cm}^3} = 1,5 \frac{\text{gr}}{\text{cm}^3} = 1,5 \frac{\text{kg}}{\text{L}}$$

$$d_B = \frac{\text{Mass}_B}{\text{Volumen}_B} = \frac{0.1 \text{ gr}}{0.1 \text{ cm}^3} = 1 \frac{\text{gr}}{\text{cm}^3} = 1 \frac{\text{kg}}{\text{L}}$$

If the ratio is 5:1 :

$$\text{Mzvol} = \text{Vol A} \div \text{Vol B} = \frac{\text{Grav. A}}{d_A} \div \frac{\text{Grav. B}}{d_B}$$

$$\text{Mzvol} = \frac{5 \text{ gr}}{1,5 \frac{\text{gr}}{\text{cm}^3}} \div \frac{1 \text{ gr}}{1 \frac{\text{gr}}{\text{cm}^3}} = 3.33 \div 1$$

3.33 proportions of volume of componet A

1 proportion of volume of componet B

# WARRANTY

M.B.P., will any repairs necessary during the first 12 months after purchase of a new unit, with the exceptions shown under 1 and 2 below, and under the conditions shown in item 3.

- 1.- Damage caused by external abuse, customer negligence, or failure to operate the unit in accordance with the instructions supplied with the unit.
- 2.- Normal maintenance items.
- 3.- Within the first 12 months after purchase, M.B.P. will pay 100% of the cost of covered repairs.

In no case will M.B.P. liability extend beyond repair or replacement of the equipment. Such liability is limited to the amount of the original purchase price paid for the unit, minus a reasonable deduction for the time the unit has been in service. It is the responsibility of the purchaser under this warranty to ship or deliver the failed paint sprayer to the authorized service center at the purchaser's expense. Parts or components covered under this warranty may either be repaired or replaced at M.B.P. option.

Equipment not covered by M.B.P. warranty. Accessories or components of equipment sold by M.B.P. that are not manufactured by M.B.P. are subject to the warranty, if any, of their manufacturer. M.B.P. will provide purchaser with reasonable assistance in making such claims.

The Industry Department of The Basque Government, states that all electric and pneumatic airless equipment manufacture by M.B.P. S.L., follows the "CE" standards under the number 83/392/CEE.

## DECLARACION DE CONFORMIDAD "CE" "EC" DECLARATION OF CONFORMITY

**MODELO / MODEL** SUPER MIX 63

Este producto cumple con la siguiente directiva de la Comunidad Europea.

This Product complies with the following European Community Directive.

Directiva 2014/34/EU Atex sobre máquinas. (Ex II 2G c T6 X)

Machinery Directive 2014/34/EU Atex Directive. (Ex II 2G c T6 X)

APROBADO POR /

APPROVED BY

AITOR ORTIZ

FECHA / DATE

MBP, S.L. figura inscrita en el Registro Industrial del País Vasco con el N° 01/8030 y cumple los requisitos para el desarrollo de su actividad comercial.

MBP, S.L. is registered in the Industrial Register of the Basque Country with the N° 01/8030.

