



## INSTRUCTIONS AND PARTS LIST

This instruction manual contains IMPORTANT WARNINGS AND INSTRUCTION THAT MUST BE READ BEFORE OPERATING THE PUMP

# HD - 20 : 1

Maximum pressure of outlet product: 140 bar  
Maximum pressure of inlet to the air motor: 7 bar



## INDEX

Symbols .....	2
Typical installation .....	4
Safety general .....	5
Pressure relief procedure.....	5
Operation and maintenance of equipment .....	6
Technical details .....	7
Parts drawing and list .....	8
Troubleshooting guide .....	11

## SYMBOLS



### WARNING

THIS SYMBOL ALERTS YOU ABOUT THE POSSIBILITY OF SERIOUS INJURIES OR DEATH IF INSTRUCTIONS ARE NOT FOLLOWED.



### CAUTION

THIS SYMBOL WARNS OF THE POSSIBILITY OF DAMAGE OR DESTRUCTION OF EQUIPMENT IF YOU DO NOT FOLLOW INSTRUCTIONS.



### WARNING



INSTRUCCIONES

### DANGER DUE TO MISUSE OF THE MACHINE

- Incorrect use can cause equipment to malfunction or even shatter and cause accidents.
- Consult the instruction's handbook before using the equipment.
- Use the equipment for its intended purpose.
- In case of doubt to consult with the distributor and not modify the machine.
- Use original spare parts from MBP
- Check periodically the equipment and replace the damaged parts.
- Do not exceed the maximum pressure in the equipment.
- Use solvents and cleaning products compatible with the equipment.
- No stragulate neither hoses nor nipple.
- Operate the hose with care. The hose can no be exposed to temperatures higher 82°C or bellow -40°C.
- Use hearing protections for equipment use.
- No move or lift the equipment with pressure.
- Bear in mind all the local procedure of safety.



## I INJECTION DANGER

- High-pressure fluid from gun, hose leaks, or ruptured components can cause severe injury.
- The fluid injection may look like a cut, but it is a sever injury. Get immediate surgical treatment.
- Do not block the leaks with your hand or with any parts of your body, even with protections
- Do not point gun at anyone or at any part of the body because it can cause sever injury.
- Do not put your hand over the spray tip.
- Do not spray without tip guard and trigger guard installed.
- Engage trigger lock when not spraying.
- When you stop spraying because you have to clean or check the equipment you must follow the pressure relief procedure.



## E TOXIC FLUID OR FUMES HAZARD

- Toxic fluids or fumes can cause serious injury if splashed in the eyes or on skin, inhaled, or swallowed.
- Know the specific hazards of the fluids you are using.
- Store hazardous fluid in approved containers.
- Use always gloves, mask, glasses and clothes to be protected from the possible hurts.



## FIRE AND EXPLOSION HAZARD

- Poor ventilation, poor grounding or a spark can create a dangerous situation, causing fires or explosions.
- Ground equipment and conductive objects in work area. See grounding instructions.
- If there is static sparking or you feel a shock, stop operation and do not use the equipment again until you identify and correct the cause.
- Use the equipment in well ventilated area.
- Keep the work area free o debris, including solvent, rags and gasoline.
- Do not smoke in the work area
- Keep a fire extinguisher in the work area.



## MOVING PARTS HAZARD

- Moving parts can pinch or amputate fingers and other body parts.
- Keep clear of moving parts
- Do not operate equipment without protective guards or covers removed.
- Before checking, moving, or servicing equipment, follow the pressure relief procedure.

## TYPICAL INSTALLATION

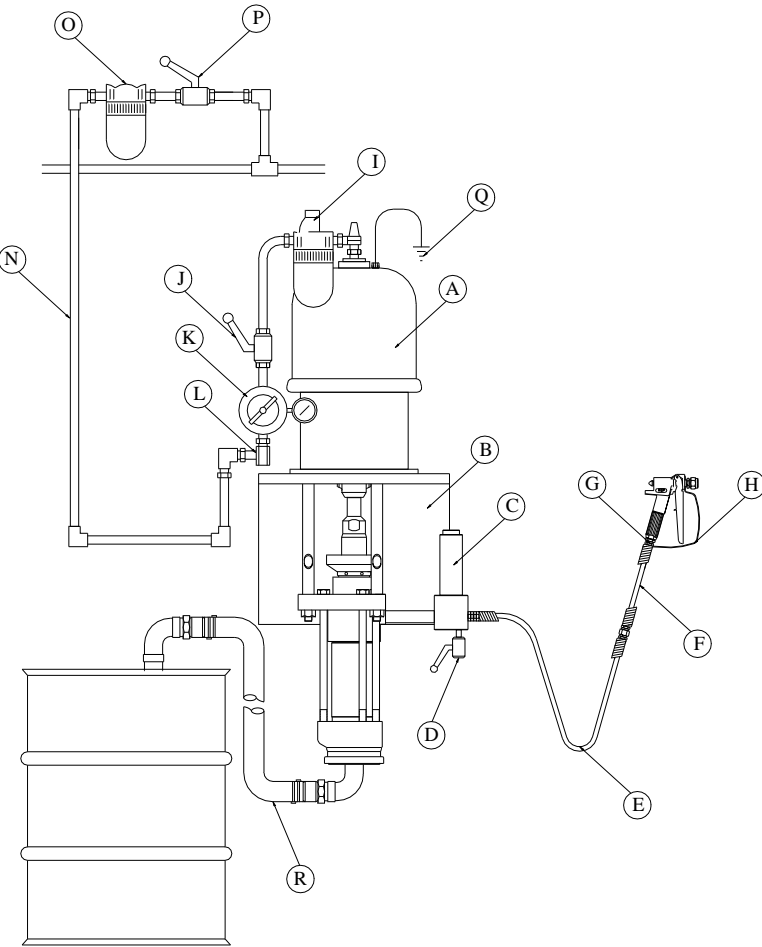

- A PUMP
- B WALL SUPPORT
- C FLUID FILTER
- D DRAIN VALVE
- E PRINCIPAL HOSE
- F FLEXIBLE HOSE
- G ROTARY COUPLING
- H GUN
- I AIR LUBRICATOR
- J AIR VALVE
- L AIR INLET
- K AIR REGULATOR
- N AIR HOSE
- O AIR FILTER
- P AIR VALVE
- Q GROUND
- R SUCTION

## GROUNDING

Before starting to work the pump must be connected to ground:

- 1.- The pump must be connected to ground with a ground wire which is supplied with the pump (4 mm<sup>2</sup> of section and a clamp).
- 2.- **SPRAY GUN:** Obtain grounding through connection to a properly grounded fluid hose and pump.
- 3.- **OBJECT BEING SPRAYED:** Use ground wire and clamp.
- 4.- **AIR COMPRESSOR:** Follow air compressor manufacturer's recommendations.
- 5.- Use **ONLY METAL PAILS**, which are conductive. Do not place the pail on a non-conductive surface, such as paper or cardboard, which interrupts the grounding continuity.



### CAUTION

In their system needed a safety valve of air (J) and a drain valve (D). The air valve (J) and the purge (D) is necessary in the installation.

These accessories help reduce the risk of serious harm, including fluid injection or fluid splash on the eyes or skin, as well as risks of moving parts if you are adjusting or repairing the pump.

The air valve cuts off air to the pump. Place the valve near the pump.

The purge helps to pressurize relief procedure. Trigger the gun may not be sufficient to depressurize the installation.

## FLUID HOSES

Make sure that the hoses (E and F) are long enough and their maximum working pressure is enough.

Use only hoses that conduct electricity.

The hoses must have spring guards on both ends.

Use a flexible hose (F) and a rotary coupling (G) between the hose (E) and gun (H) for the movement of the gun is more manageable and comfortable.



### WARNING

Do not lift the pump by lifting the ring when the total weight exceeds 250 kgs.

Mount the pump (A) according to the type of installation shown. Fig 2 illustrates a system installed in a wall

## PNEUMATIC ACCESSORIES INSTALLATION

Installation accessories in the order shown in figure 2, using adapters if necessary. Install the accessories in the order shown in figure 2, use adapters if necessary.

### Air lubricator (I).

Automatically lubricates the motor.

### Air valve (J).

It cuts off air to the pump. Make sure the valve is easily accessible and it must be installed after the air regulator.

### Air Regulator (K)

It controls the pump speed and outlet pressure of the product. Install the regulator near the pump, but before the air valve (J).

### Air inlet (L).

It has an air inlet. Installed in a wall.

### Air filter (O).

It separates dirt from the air inlet.

### Air valve (P).

It cuts the air intel from the air line isolate the air line accessories for servicing. Located upstream of the other pneumatic accessories. Istalled bet ween the air line and the installation.

## ACCESSORIES FLUID.

Install the accessories in the positions shown in fig 2, use adapters if necessary.

### Fluid filter (C).

Stainless steel filter 60 mesh (250 micron), if filters the particles that carries the product. Includes a purge (D), which is necessary to eliminate the pressure of the circuit.

### Gun or valve (H).

It dispenses the product.

### Rotary coupling (G).

It allows a smoother movement of the gun.

### Suction (R).

It allows the pump to absorb the product.



### CAUTION

If you notice that the regime of pumping, increases suddenly at a speed considerably higher, close the in valve (J) and check if the pump has absorbed the whole product of the deposit and if the pump is absorbing air. Replace the product and feed the pump again.

## GENERAL SAFETY



### CAUTION



### DANGER OF INJECTION

Equipment is pressurized until you remove the pressure. To reduce the risk of accidents you must remove the pressure when:

- A- You have finished dispense product.
- B- You change product deposit.
- C- You are going to give service to any of the parts of the installation or from your computer.
- D- Review, inspect or install new elements.

## PRESSURE RELIEF PROCEDURE

- Engage the gun safety latch.
- Close the regulator (K) and close the air valve (J).
- Disengage the gun safety latch.
- Hold a metal part of the gun firmly to the side of a grounded metal pail, and trigger the gun safety latch.
- Engage the gun safety latch.
- Open the drain valve (D), having a grounded metal container ready to catch the drainage.
- Leave the drain valve open until you are ready to spray again.



### CAUTION



#### DANGER OF BREAKAGE OF COMPONENTS.

The working pressure may not be the same in all components of the installation. Must inform of the working pressure for each of the components to reduce the risk of accidents.

Can not exceed the working pressure of the component that support lower pressure.

## OPERATION AND MAINTENANCE OF EQUIPMENT

From the beginning to the end of the maintenance is necessary that the machine is disconnected from the pressured air source and completely eliminate the pressure inside the machine.

### NOTE:

In case of injection of material (paint, solvent, varnish, etc.) into any part of the body, to call a doctor and inform of the type of product used is necessary.

## PACKING NUT

Fill in the packing nut 1/3 full MBP packoil or compatible solvent.



### WARNING

Before any maintenance is necessary to remove the pressure of the installation (Pressure Relief Procedure).

The packing nut is tightened at the factory but if there is a product leak, the packing nut must be tightened using the tool provided.

This operation should be performed whenever necessary.

Do not over tighten the packing nut. Because it would cause premature wear on the packing.

## START-UP

Start and adjustment of the pump.

- 1.- See «typical installation» on pag 4. Connect the suction (R) to the pump and introduce it inside the product jerry can.
- 2.- Make sure the air regulator (K) is closed (0 bar). Open the air valve (J). Keep the gun in contact with metal deposit, which has to be grounded, and keep the trigger pressed. Slowly open the air regulator (K) until the pump begins to operate.

- 3.- Operate the pump slowly until all the air has been removed. The pump and the hose must be full of fluid. Release the gun trigger engage the gun safety latch. Pressure, the pump should immediately stop.

- 4.- If the product is very viscous and the pump can not suck the product, open the drain valve (D). Close the drain valve (D) when the product go through it.



### CAUTION

The pump can not operate without product. If the product is finished, the pump will suck air causing an acceleration into its operation. Stop the pump when it start working very fast.

- 5.- When the pump and the circuit are fed, the pump will move and stop as you open or close the gun trigger. In a re-circulation system, the pump will work faster or slower depending on demand, until the air supply is closed.

- 6.- The speed of operation of the pump and the outlet pressure of the product are regulate by the air regulator (K). Always use the minimum air pressure to achieve the desired results. A higher working pressure, the abrasion is greater.

## CLEANING

Turn off the air regulator (K), and the air valve (J).

Open the drain valve (D), to relieve pressure.

Supply the pump with comparatible solvent. Turn on the air regulator (K) and the air valve (J)

Close the drain valve (D) when the solvent comes out of it.

Press the trigger of the gun until the solvent, which comes out of it, is clean.

Turn off the air regulator (K) and the valve (J).

Open the drain valve (D) to relieve pressure.

# TECHNICAL DETAILS

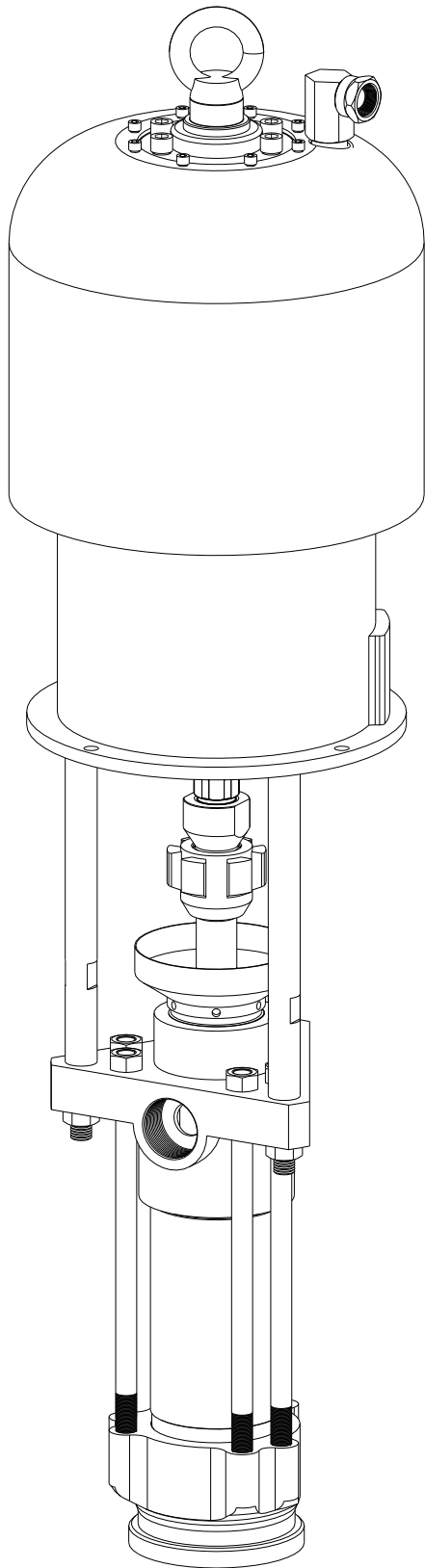

PUMP RATIO	20:1
RECOMMENDED MAX. SPEED	50 cycles/min
FLOW AT 50 CYCLES	46 litres
MAX. AIR INLET PRESSURE	7 bar
MAX. FLUID PRESSURE	140 bar
AIR INLET	3/4" GAS
PRODUCT INLET	2" GAS
PRODUCT OUTLET	1 1/2" GAS
WEIGHT	70 kgs

# AIR MOTOR

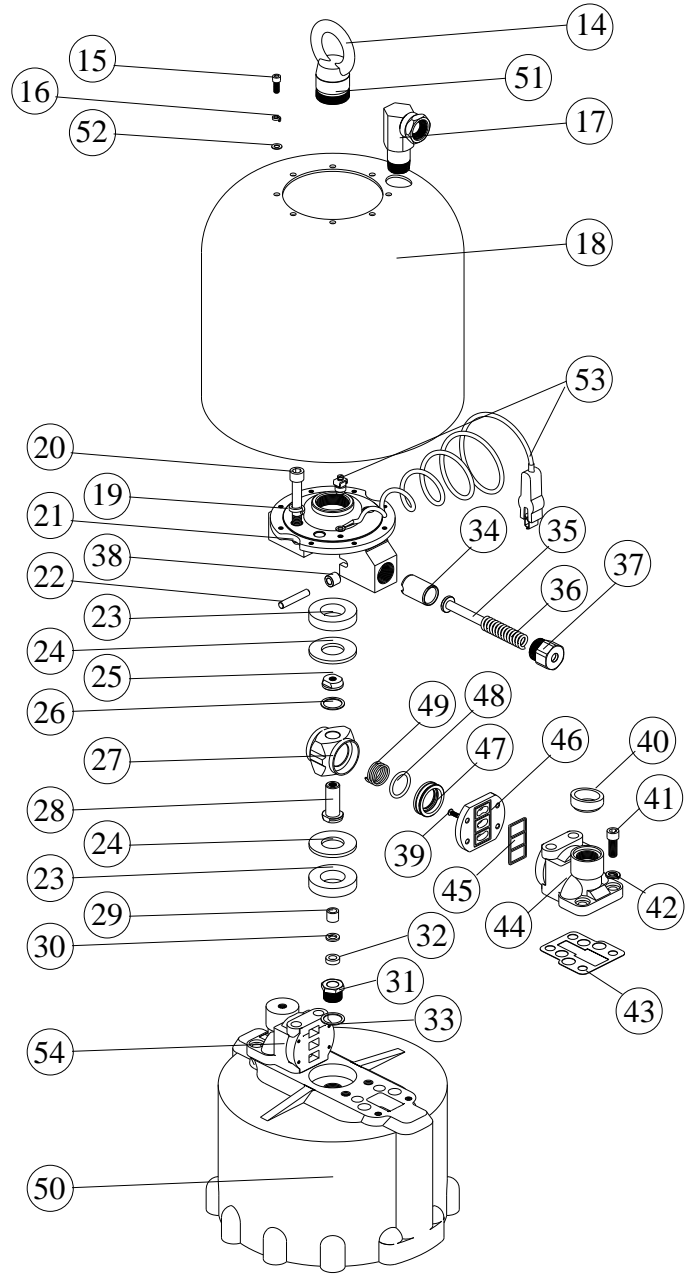
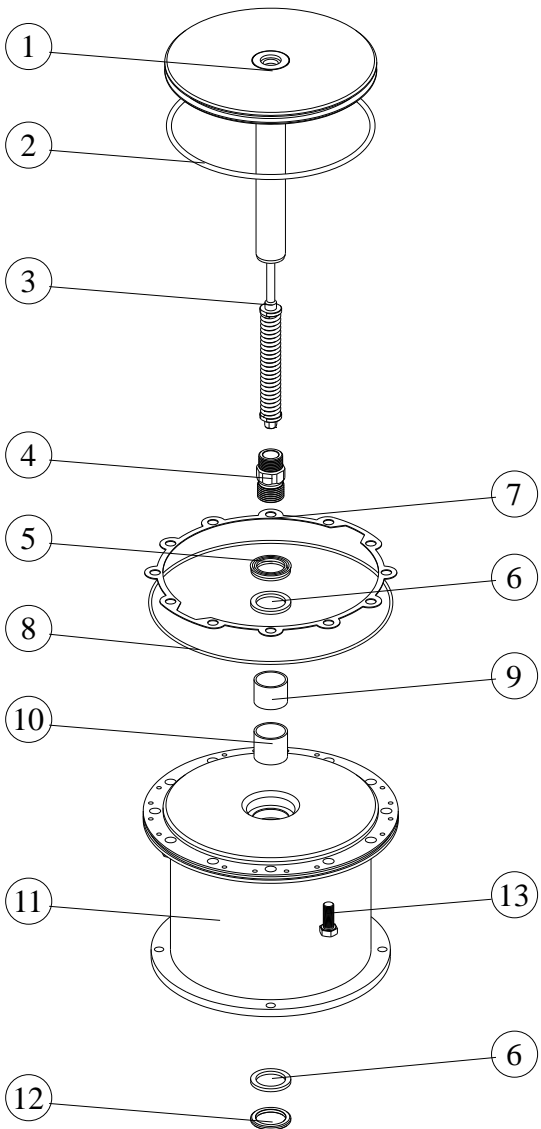



Nº	REF.	DESCRIPTION	Q
1	A.421.00	PISTON	1
2	CJT.018	O-RING	1
3	A.422.00	SHAFT	1
4	A.420.01	CONNECTOR	1
5	CAB.008	PACKING	1
6	A.430.03	JOINT	2
7	A.400.03	JOINT	1
8	CJT.019	O-RING	1
9	CB2.009	SLEEVE	1
10	CB2.010	SLEEVE	1
11	A.430.01	MOTOR BODY	1
12	A.430.02	JOINT	1
13	CTT.008	SCREW	12
14	CTU.141	EYRE	1
15	CTT.006	SCREW	8
16	CTT.007	SPRING WASHER	8
17	A.440.00	AIR INLET RACOR	1
18	A.400.01	HOUSING	1
19	CTT.005	SPRING WASHER	4
20	CTT.004	SCREW	4
21	A.410.08	SUPPORT	1
22	CPA.213	PIN	2
23	A.410.02	JOINT	2
24	A.410.03	SEAT	2
25	A.410.18	NUT	1
26	CAR.053	SPRING WASHER	1
27	A.410.17	AIR VALVE HOUSING	1

Nº	REF.	DESCRIPTION	Q
28	A.410.19	HUB	1
29	A.411.03	SLEEVE	1
30	A.411.04	JOINT	1
31	A.411.01	CONNECTOR	1
32	CAB.007	PACKING	1
33	CAR.012	JOINT	1
34	A.410.10	PLUNGER	2
35	A.410.12	SPRING DETENT	2
36	A.410.11	SPRING	2
37	A.410.13	SPRING RETAINER	2
38	A.410.09	ROLLER	2
39	CTT.002	SCREW	8
40	A.400.02	JOINT	1
41	CTT.001	SCREW	4
42	CTT.003	SPRING WASHER	4
43	A.410.04	JOINT	2
*44	* A.410.05A	VALVE BODY	1
45	A.410.07	JOINT	2
46	A.410.06	VALVE SEAT	2
47	A.410.15	VALVE	2
48	CJT.001	O-RING	2
49	A.410.16	SPRING	2
50	A.410.01	CYLINDER	1
51	A.410.14	SPRING	1
52	CAR.021	WASHER	8
53	TIE.GR	GROUND	1
*54	*A.410.05B	VALVE BODY	1

44.-\* Valve body threaded

54.-\* Valve body without thread

# DISPLACEMENT PUMP

N°	REF.	DESCRIPTION	Q
1	A.420.01	CONNECTING ROD	1
2	108.200.12	NUT	1
3	108.200.09	BEARING	2
4	108.200.11	NUT	1
5	108.200.01	ROD	1
6	108.210.00	PACKING NUT	1
7	108.250.01	FEMALE GLAND	1
8	108.250.02	MALE GALND	1
*9	108.250.03	PACKING POLYETH	4
*10	108.250.04	PACKING	3
11	108.200.10	TIE	3
12	CTU.104	NUT	3
14	108.270.00	CAPSCREW	6
15	108.240.00	HOUSING	1
16	108.200.06	BALL GUIDE	1
17	108.260.02	MALE GLAND	1
18	108.260.01	FEMALE GLAND	1
*19	108.260.03	PACKING POLYETH	3
*20	108.260.04	PACKING	2
21	CBO.117	BALL	1
22	108.220.00	PISTON	1
*23	108.200.05	JOINT	2
24	108.200.02	CYLINDER	1
25	108.200.04	BALL GUIDE	1
26	CBO.116	BALL	1
27	108.230.00	BODY SEAT	1
*28	108.200.08	JOINT	1
29	108.200.03	HOUSING	1

\* Included in KIT.048

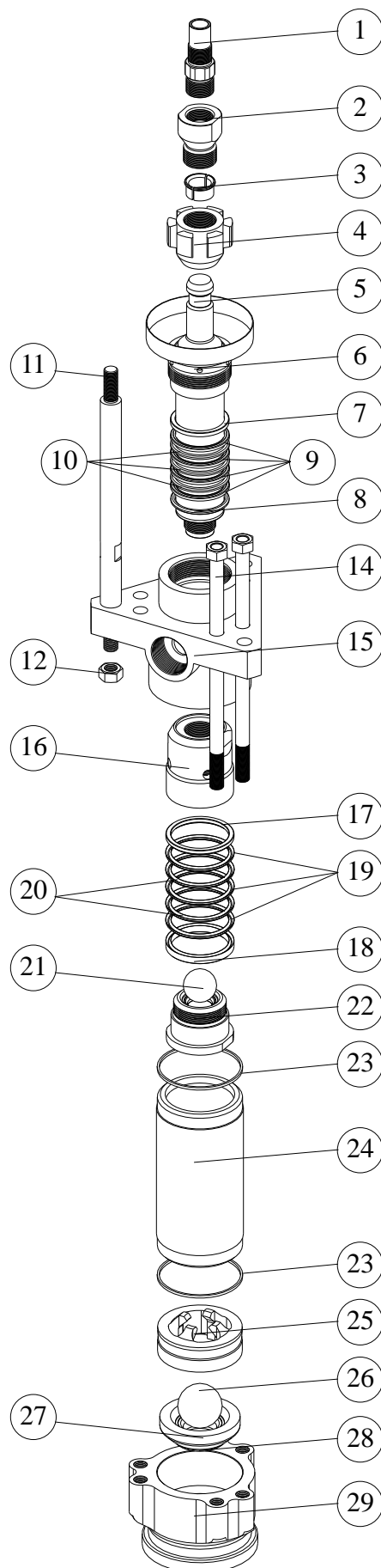

## TROUBLESHOOTING GUIDE

PROBLEM	POSSIBLE CAUSE	SOLUTION
Pump. fails to operate.	Restricted line or inadequate air supply.	Clear, increase air.
	Insufficient air pressure, closed or clogged air valves, etc.	Open, clean.
	Exhausted fluid supply.	Refill; purge all air from pump and fluid lines.
	Obstructed fluid hose, gun or dispensing valve.	Clear.
	Clogged spray tip or filters.	Clear or replace.
Pump operates but output low on down stroke.	Clogged filters.	Clear or replace.
	Throat packings nut too tight or too loose.	Adjust.
	Exhausted fluid supply.	Refill and prime.
	Obstructed fluid hose or gun.	Clear.
	Worn spray tip.	Replace.
	Held open or worn intake valve.	Clear.
	Held open or worn fluid piston or packings.	Clear or replace.
Erratic or accelerated operating.	Exhausted fluid supply.	Refill and prime.
	Check valves need adjustment.	Adjust.
	Held open or worn intake valve.	Clear.
	Held open or worn fluid piston or packings.	Clear or replace.
<p>For trouble free operation is absolutely essential that your sprayer be kept clean and free of residual paint build-up on the internal parts. It must be cleaned and lubricated after each use.</p>		

## WARRANTY

M.B.P., will any repairs necessary during the first 12 months after purchase of a new unit, with the exceptions shown under 1 and 2 below, and under the conditions shown in item 3.

- 1.- Damage caused by external abuse, customer negligence, or failure to operate the unit in accordance with the instructions supplied with the unit.
- 2.- Normal maintenance items.
- 3.- Within the first 12 months after purchase, M.B.P. will pay 100% of the cost of covered repairs.

In no case will M.B.P. liability extend beyond repair or replacement of the equipment. Such liability is limited to the amount of the original purchase price paid for the unit, minus a reasonable deduction for the time the unit has been in service. It is the responsibility of the purchaser under this warranty to ship or deliver the failed paint sprayer to the authorized service center at the purchaser's expense. Parts or components covered under this warranty may either be repaired or replaced at M.B.P. option.

Equipment not covered by M.B.P. warranty. Accessories or components of equipment sold by M.B.P. that are not manufactured by M.B.P. are subject to the warranty, if any, of their manufacturer. M.B.P. will provide purchaser with reasonable assistance in making such claims.

The Industry Department of The Basque Government, states that all electric and pneumatic airless equipment manufacture by M.B.P. S.L., follows the "CE" standards under the number 83/392/CEE.

### DECLARACION DE CONFORMIDAD "CE" "EC" DECLARATION OF CONFORMITY

**MODELO / MODEL** HD - 20

Este producto cumple con la siguiente directiva de la Comunidad Europea.

This Product complies with the following European Community Directive.

Directiva 2014/34/EU Atex sobre máquinas. (Ex II 2G c T6 X)

Machinery Directive 2014/34/EU Atex Directive. (Ex II 2G c T6 X)

APROBADO POR /

APPROVED BY

AITOR ORTIZ

FECHA / DATE

MBP, S.L. figura inscrita en el Registro Industrial del País Vasco con el N° 01/8030 y cumple los requisitos para el desarrollo de su actividad comercial.

MBP, S.L. is registered in the Industrial Register of the Basque Country with the N° 01/8030.

