



INSTRUCTIONS AND PARTS LIST

This instruction manual contains IMPORTANT WARNINGS AND INSTRUCTION THAT MUST BE READ BEFORE OPERATING THE PUMP

HYDRAULIC RATIO 46:1

MODELS TEL 46BS°TEL 46CS



INDEX:

WARNINGS.....	2
TYPICAL INSTALLATION.....	3
PRESSURE RELIEF PROCEDURE.....	3
HOSE SAFETY.....	3
SPRAY GUN & OPERATING INSTRUCTIONS.....	3
MAINTENANCE (CLEANING AND FLUSHING).....	3
SPRAY TIPS.....	4
PARTS DRAWING AND LIST	4, 5 & 6
DISPLACEMENT PUMP REPAIR	7
SERVICE HD-AIR MOTOR	8
TROUBLESHOOTING GUIDE	10
TECHNICAL DATA	10
STANDARD SPRAY TIPS	10
WARRANTY.....	11

WARNING

ATTENTION!! Read and understand all instructions carefully before operating equipment.

INJECTION HAZARD

This equipment generates very high fluid pressure. Spray from the gun, leaks or ruptured components can inject fluid through your skin and into your body and cause extremely serious bodily injury.

The spray gun should never be handled carelessly, nor spray directed toward any part of the body. Keep your hands and fingers away from spray gun nozzle.

Be sure equipment safety devices are operating properly before each use.

If any fluid appears to penetrate your skin, get emergency medical care at once. Do not treat as a simple cut. Tell the doctor exactly what fluid was injected.

FIRE HAZARD

Static electricity is created by the high velocity flow of fluid through the pump and hose. If every part of spray equipment is not properly grounded, sparking immediately. Check the entire system for positive grounding.

GROUNDING

Before starting to work the pump must be connected to ground:

- 1.- The pump must be connected to ground with a ground wire which is supplied with the pump (4 mm² of section and a clamp). See connection on page 6.
- 2.- SPRAY GUN: Obtain grounding through connection to a properly grounded fluid hose and pump.
- 3.- OBJECT BEING SPRAYED: Use ground wire and clamp.
- 4.- AIR COMPRESOR: Follow air compressor manufacturer's recommendations.
- 5.- Use **ONLY METAL PAILS**, which are conductive. Do not place the pail on a non-conductive surface, such as paper or cardboard, which interrupts the grounding continuity.

TYPICAL INSTALLATION

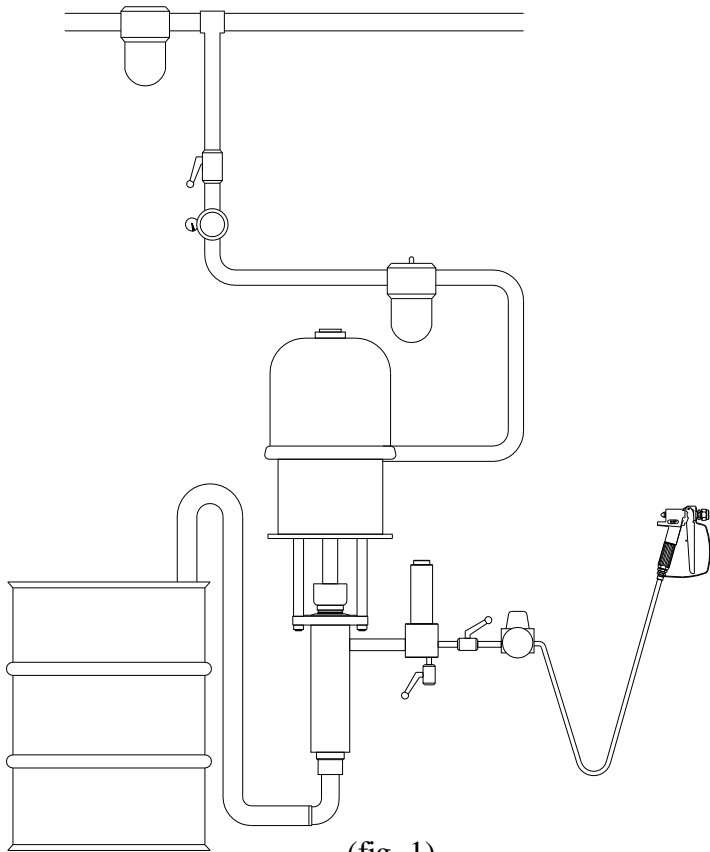

(fig. 1)

PRESSURE RELIEF PROCEDURE

- 1.- Engage the gun safety latch.
- 2.- Shut off the air to the pump.
- 3.- Close the air inlet valve.
- 4.- Disengage the gun safety latch.
- 5.- Hold a metal part of the gun firmly to the side of a grounded metal pail, and trigger the gun safety latch.
- 6.- Engage the gun safety latch.
- 7.- Open the drain valve, having a grounded metal container ready to catch the drainage.
- 8.- Leave the drain valve open until you are ready to spray again.

HOSE SAFETY

Tighten all fluid connections securely before each use. Never use a damaged hose. Before each use, check entire hose for cuts, leaks, abrasions, bulging cover, or damage or movement of the hose couplings. If any of these conditions exist, replace the hose immediately.

SPRAY GUN

It is recommended strain the fluid you are spraying if it contains particles which could clog the spray tip.

CLEANING THE SPRAY TIP

Clean off the front of the tip frequently during the day's operation and at the end of the work day. Always follow the Pressure Relief Procedure on page 3. Then use a solvent soaked brush to clean the spray tip and to keep fluid buildup from drying and clogging the spray tip.

If the spray tip clogs while spraying, release the spray gun trigger, engage the trigger safety, shut off the pump, and follow the Pressure Relief Procedure. Remove the spray tip and blow out the obstructions with air from the front of the spray tip.

Normal daily flushing of your spray system and gun flushes away most buildup on the filter. However, you should remove the filter frequently and clean it.

FLUSHING THE GUN

Relieve pressure, remove the spray tip, and then flush the gun and spray system with a compatible solvent. Always flush the gun before the fluid being sprayed can dry in it.

OPERATING INSTRUCTIONS

Follow all instructions above, be sure that fittings at pump outlet and at gun are tight. Use two wrench to tighten the main fitting. Do not install the spray tip at this time.

Fill the packing nut with oil to help prolong the packing life.

Put the suction tube into the paint container. Flush the pump with a compatible solvent before using it.

Open the air inlet valve. Disengage the gun safety and trigger the spray gun into a grounded metal pail, and slowly open the air supply valve until the pump starts (about 3 or 4 bar). The lines are purged when the fluid emitted from the gun is flowing in a steady stream. Engage the gun safety, shut off the air inlet valve then install the spray tip in the gun.

Open the air inlet valve. When the pump and the lines are primed, and adequate air pressure and volume are supplied, the pump will start and stop as the spray gun is triggered and released.

Disengage the gun safety and you are now ready to spray!!

MAINTENANCE (CLEANING AND FLUSHING)

It is recommended that at the end of each day, paint should be flushed from unit with compatible solvent then refushed with mineral spirits.

- 1.- Engage the gun safety and follow the Pressure Relief Procedure.
- 2.- Remove the spray tip and clean with a compatible solvent and soft brush.
- 3.- Disengage the gun safety and follow the pressure relief procedure. Lift suction tube above paint level until tube is empty.
Introducing the suction tube in a pail with compatible solvent. Disengage gun safety and trigger gun into the pail until it runs clear. Close the air inlet valve.
- 4.- Open the fluid drain valve. Remove the fluid filter and the gun filter and clean them with solvent.
- 5.- Flush the sprayer at the end of each work day and fill it with solvent to help prevent pump corrosion.

PARTS LIST

- 1.- AIR MOTOR
- 2.- DISPLACEMENT PUMP
- 3.- AIR LINE FILTER AND AIR REGULATOR
- 4.- FLUID SUCCION LINE
- 5.- FLUID DRAIN VALVE
- 6.- AIR INLET VALVE
- 7.- FLUID FILTER
- 8.- PACKING NUT
- 9.- FLUID HOSE
- 10.- GUN
- 11.- SAFETY KNOB
- 12.- GROUND CONNECTION

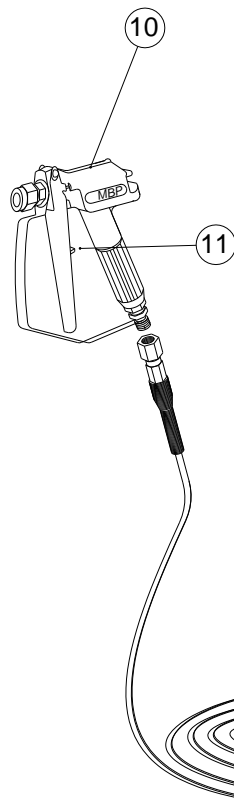

SPRAY TIPS

When a tip is the wrong size, or becomes the wrong size through wear, the spray pattern worsens, coverage decreases, you have less control over the desired rate of coverage, and it takes longer to finish the job. In the worst case, the pump supplying the tip can be damaged. Because most architectural coating are abrasive, tip wear can happend quite quickly. Notice as wear increases the orifice size, it decreases the fan width which greatly affects coverage rates.

If tip shows excessive wear, replace it to maximize productivity and save paint.

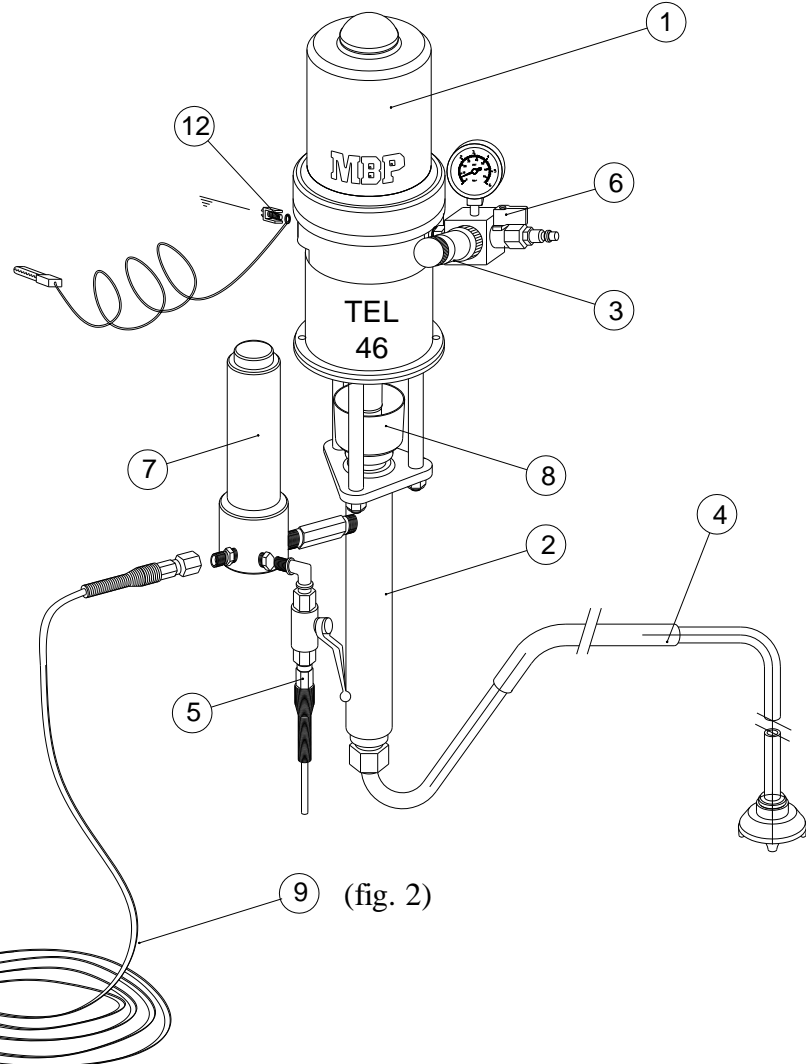

DISPLACEMENT PUMP

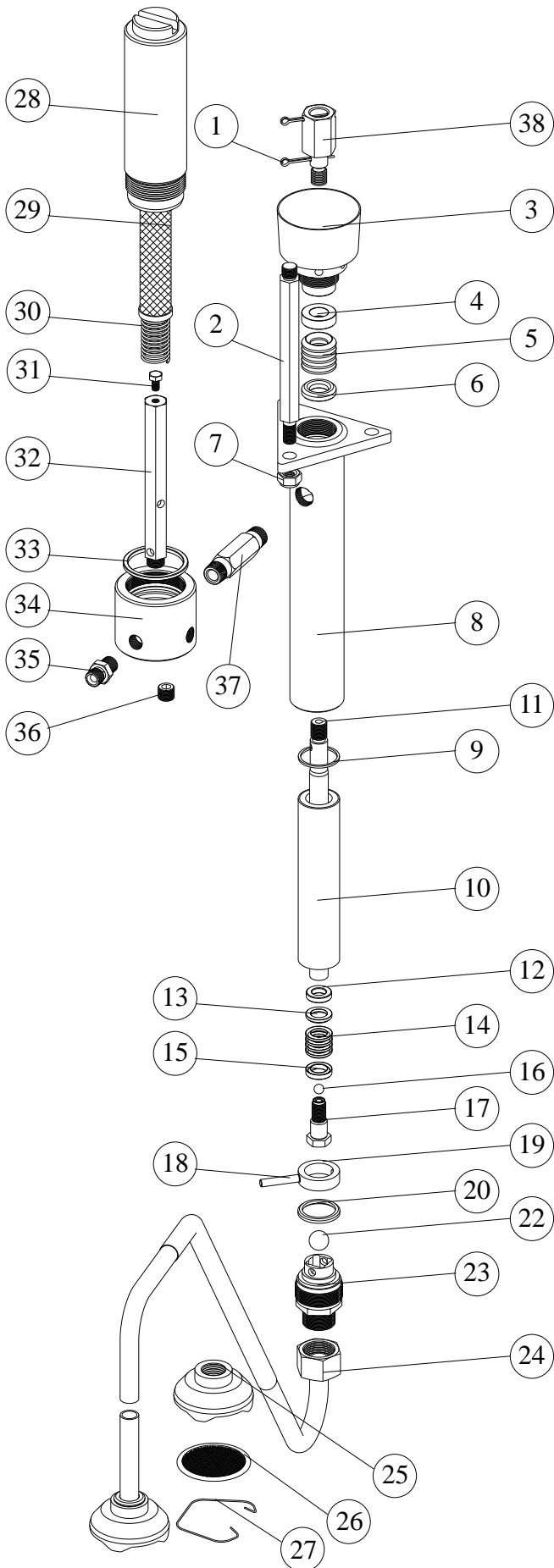

(fig. 3)

N°	REF.	DESCRIPTION	Q
1	CPA.101	PIN	2
2	C.201.01	TIE	3
3	B.120.00	PACKING NUT	1
*4	B.131.01	FEMALE GLAND	1
*5	B.131.02	PACKING	5
*6	B.131.03	MALE GLAND	1
7	CTU.101	NUT	3
8	B.110.00	HOUSING	1
9	B.100.01	JOINT	1
10	B.100.12	SLEEVE	1
11	B.100.13	ROD	1
12	B.141.01	WASHER	1
*13	B.141.02	MALE GLAND	1
*14	B.141.03	PACKING	4
*15	B.141.04	FEMALE GLAND	1
16	CBO.101	BALL	1
17	B.151.00	PISTON	1
18	B.100.05	PIN	1
19	B.170.01	RETAINER	1
20	B.100.06	JOINT	1
22	CBO.104	BALL	1
23	B.171.00	VALVE	1
24	D.100.00	FLUID SUCCION	1
25	D.130.01	BODY	1
26	D.132.00	FILTER	1
27	D.130.02	SPRING	1
28	G.100.02	COVER	1
29	G.100.XX*	FILTER	1
30	G.100.04	SPRING	1
31	CTA.901	SCREW	1
32	G.100.03	SUPPORT	1
33	G.100.07	JOINT	1
34	G.100.01	BODY	1
35	G.100.06	RACORD	1
36	CTF.001	PLUG	2
37	G.100.08	RACORD	1
38	C.201.02	UNION ROD	1

* G.100.20 FILTER 60 MESH
 G.100.05 FILTER 100 MESH
 G.100.21 FILTER 200 MESH

*** Included in KIT.002**

NOTE: Fix parts 11 and 17 with loctite 542 or similar (wait 1 hour before start running the unit)

AIR MOTOR

N°	REF.	DESCRIPCION	Q
1	A.110.02	CAP	1
2	CJT.001	JOINT	1
3	A.210.01	CYLINDER	1
4	A.120.04	ROD	2
5	A.220.07	SUPPORT	1
6	A.120.08	YOKE	1
7	A.221.00	ROD	1
8	CTJ.002	SCREW	2
9	A.240.02	CLIP	2
10	A.240.01	PISTON	1
*11	A.122.00	STEM	2
*12	CJT.005	JOINT	1
13	A.220.11	ROD	1
*14	CJT.007	JOINT	1
15	CB2.015	SLEEVE	1
*16	CJT.006	JOINT	1
17	A.130.02	PLATE	2
18	A.250.01	BASE	1
19	CTA.001	SCREW	6
20	CTC.001	SCREW	16
21	A.120.01	ROCKER	2
22	A.120.02	SPRING	2
23	A.120.03	ROD	2
*24	A.120.05	CLIP	2
25	A.120.06	NUT	4
26	A.150.02	JOINT	1
*27	A.120.10	JOINT	2
*28	A.220.09	JOINT	2
29	CAR.125	RETAINER	1
30	TIE.GR	GROUND	1

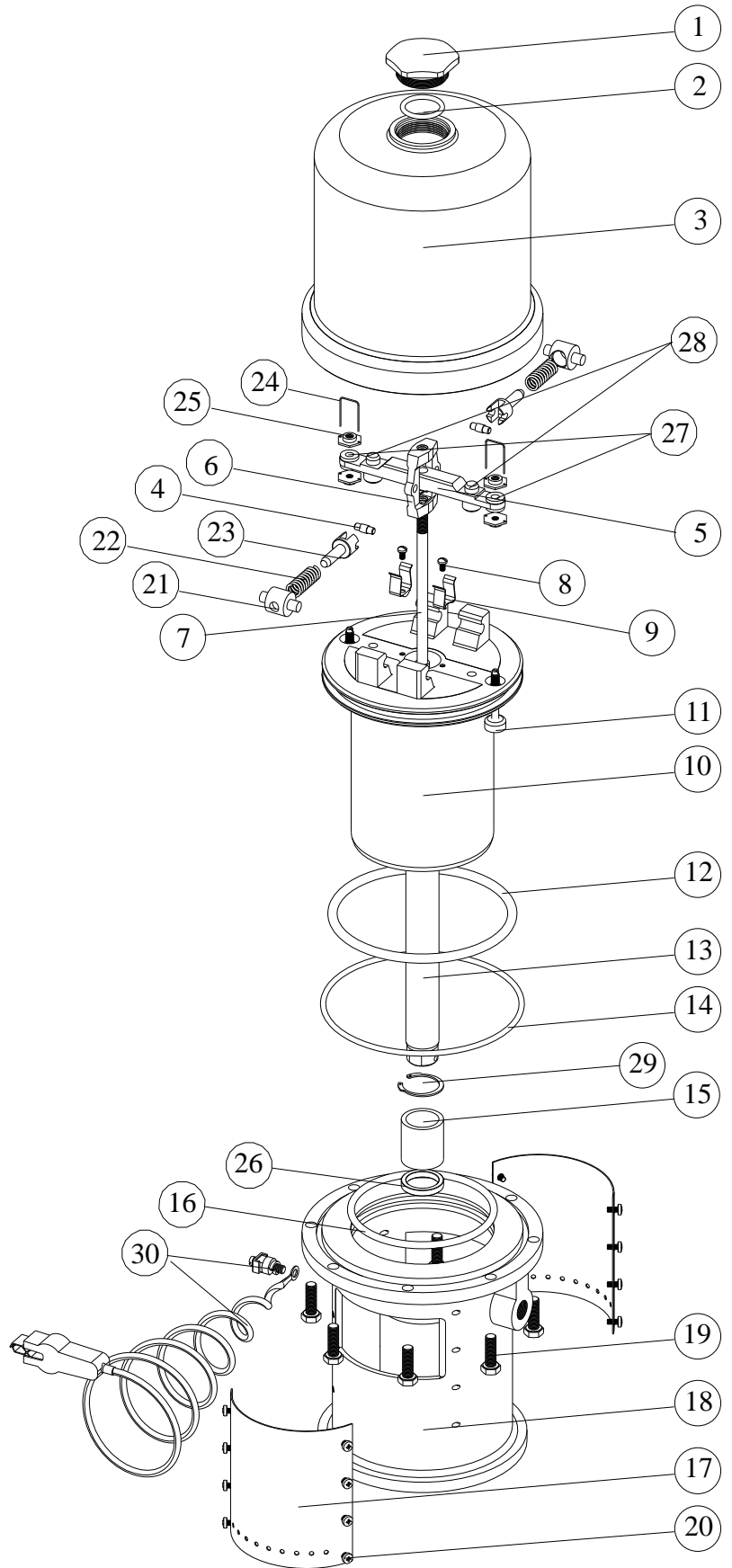

(fig. 4)

* Included in KIT.054

DISPLACEMENT PUMP SERVICE

NOTES:

- 1.- Repair Kit is available for Pumps. For the best results, use all the new parts, even if the old parts look good.
- 2.- Clean all the parts thoroughly when disassembling. Check them carefully for damage or wear, replacing parts as needed.

INTAKE VALVE .

Screw the intake valve housing (20) out of the outlet housing (8). If the valve is seized in the housing, squirt penetrating oil around the threads and gently tap around the housing with a plastic hammer to loosen. See fig.5.

Remove the ball stop pin (15), guide (16), joint (17), and the ball (19). Reassemble the valve, using new parts as necessary, and screw it back into the pump housing.

PISTON, SLEEVE OR DISPLACEMENT ROD.

Screw the intake valve housing (20) out of the outlet housing (8). Loosen the tie rod locknuts (2). Disconnect the displacement rod (11) from the air motor (18) piston rod by removing the cotter pin (1), then unscrewing the connecting rod (18) or displacement rod. Remove from the tie rods (7). Loosen the packing nut (3) and push the displacement rod down out of the housing. Secure the flats of the rod in a vise. Screw the piston seat (14) out of the rod. Remove the ball (13), retainer (12), packings (5) and glands (4, 6).

Scoring or irregular surfaces on the displacement rod or polished inner wall of the sleeve cause premature packing wear and leaking. Check these parts by rubbing a finger on the surfaces or by holding the parts up to a light at an angle. Replace worn parts. If the sleeve needs replacing, be sure to install a new sleeve with the tapered end down.

If it is necessary to replace the sleeve (10), you have to replace the joint (9) that is between the pump housing (8) and the sleeve (10).

Install the packings on the piston as instructed below. Be sure the lips of the v-packings face UP, against fluid pressure. Lubricate the packings with grease compatible with the fluid being pumped. Always use new glands with new packings for a good seal.

One at a time, install a female gland (4) an v-packings (5), a male gland (6), and the packing retainer (12) onto the piston (14). See fig.5.

Use thread sealer (loctite 542) on the piston seat and stud. Install the piston, packings, and ball (13) into the displacement rod (11). Torque the piston to 65-75 ft-lb (88-102 N-m).

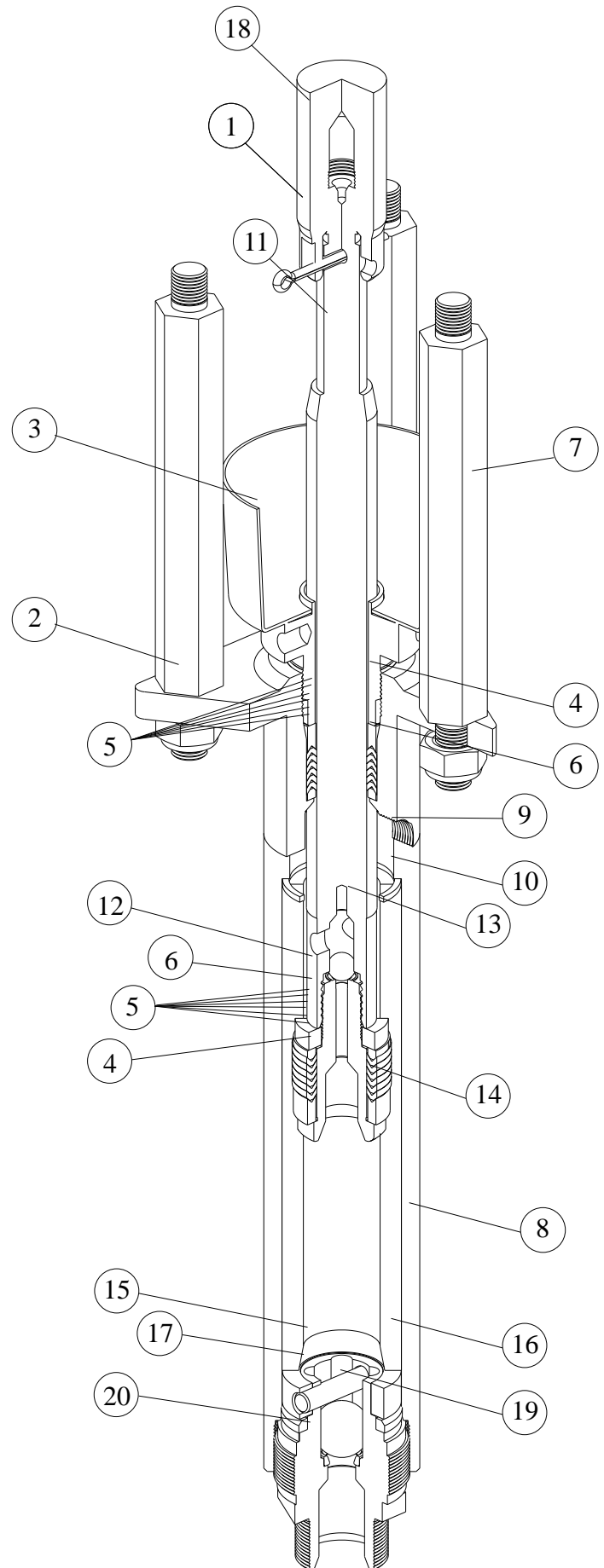

(fig. 5)

THROAT PACKINGS.

Screw the intake valve housing (20) out of the outlet housing (8) and remove the piston and displacement rod as explained to the left. Then screw the packing nut (3) out of the housing (8) and take the packings (5) and glands (4, 6) out of the cavity.

Install the throat packings as instructed below. Be sure the lips of the v-packings face down, against fluid pressure. Lubricate the packings with grease compatible with the fluid being pumped. Always use new glands with the new packings.

One at a time, install a male gland (6), v-packings (5), and a female gland (4) into the throat of the pump housing (8). See fig.5.

Reassemble the pump in reverse order of disassembly. Check the tie rods to be sure that they are tightened securely into the air motor base. Assemble the connecting rod to the air motor and screw the locknuts loosely onto the tie rods. Tighten the packing nut until it's just snug. Finish tightening the locknuts evenly to 35-50 ft-lb (47-68 N.m) Then tighten the packing nut just enough to stop leakage-no tighte. Start the pump and run it at 40 psi (3 bar) minimum air pressure to check the tie rods for signs of binding. Adjust if necessary.

Note:

If the grounding wire was disconnected before servicing, be sure to reconnect it before operating the pump.

SERVICING THE AIR MOTOR

RESTARTING A STALLED AIR MOTOR.

To reseat the air transfer valves and restart a stalled air motor, relieve the air supply pressure to the motor by closing the air valve. If the air transfer valves fail to reseat, screw the cap nut (1) out of the cylinder (3), pull up on the trip rod (7) and screw the cap nut back into the cylinder. See fig.6. Be sure the air supply pressure is less than 12 bar (180 psi) before opening the air valve.

DISASSEMBLING AND REASSEMBLING THE AIR MOTOR.

Manually push on the piston rod to move the piston to the top of its stroke. Screw the cap nut (1) out of the cylinder (3). Pull up on the cap nut, grip the trip rod (7) with padded pliers (A-A) and screw the cap nut off of the trip rod. See fig. 6.

Do not damage the plated surface of the trip rod. Damaging the surface of the trip rod can result in erratic air motor operation.

Remove the screws (19) holding the cylinder (3) to the base (18) and carefully pull the cylinder straight up off of the piston. See drawing 6. Always keep fingers clear of the toggle assemblies (X), to avoid pinching or amputating them.

Use a screwdriver to push down on the trip rod yoke (6) and snap the toggle assemblies (X) down. Remove the lockwires (24) and upper adjusting nuts (25) from the air transfer valves (H). Screw the valve stems (11) out of the grommets (27) and lower adjusting nuts (25) and inspect them for cracks. See fig. 7.

Grip the toggle rocker (21) with pliers, compress the spring (22), swing the toggle assembly (X) up and away from the piston lugs (10) and remove the parts. See fig. 7. Inspect the valve actuator (5) to be sure it is supported by the spring clips (9), but slides into them easily. Remove the trip rod yoke (6), valve actuator (5) and the trip rod (7). Check the exhaust valve poppets (28) for cracks. Pull the piston (10) up out of the base (18) and inspect the o-ring (12) in the base casting (10).

To remove the exhaust valve poppets (28), stretch them out and cut them with a sharp knife.

Clean all parts thoroughly and inspect for wear or damage. Replace parts as necessary. Inspect the polished surfaces of the piston, piston rod and cylinder walls for scratches or wear. Lubricate all parts with a light waterproof grease. Be sure the o-rings are in place, slide the piston rod down through the throat bearing and lower the piston (10) into the base (18).

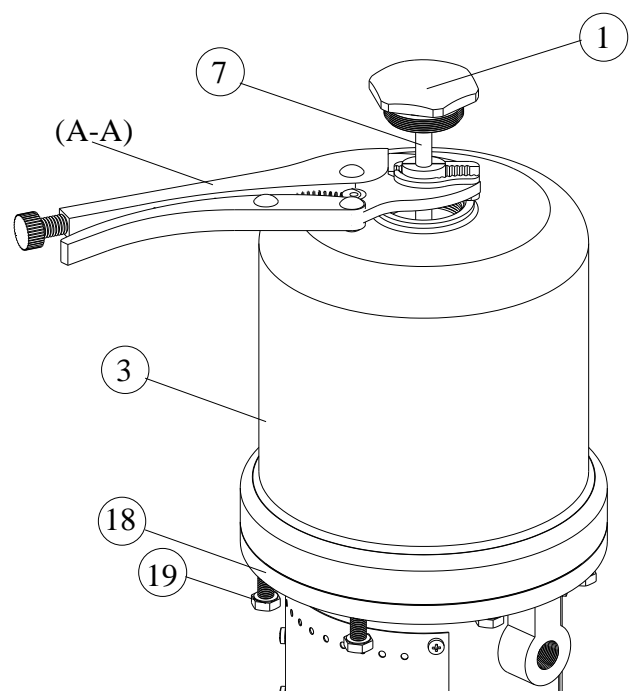

(fig. 6)

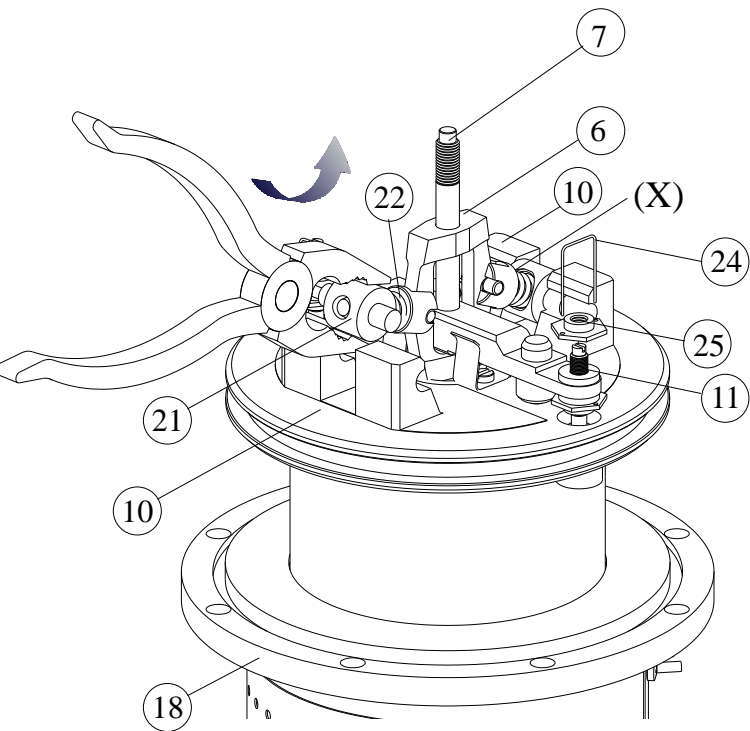

(fig. 7)

Pull the exhaust valve poppets (28) into the valve actuator (5) and clip off the top part shown with dotted lines. See fig. 8 and 9. Reassemble the valve stems (11), grommets (27), adjusting nuts (25) trip rod (7), valve actuator (5), trip rod yoke (6) and the toggle assemblies (X) on the piston (10). See fig. 8.

Adjust the valve stems (11) so there is a 4,17 mm. clearance between the valve poppets (11) and the piston (10) when the toggle assemblies are in the down position. See fig. 8.

Be sure the toggle assemblies (X) are in the up position and then reinstall the cylinder (3) and the cap nut (1). See fig. 6. Reassemble the air motor to the displacement pump. Before mounting the pump, connect an air hose to the air motor and run the pump to be sure it operates smoothly.

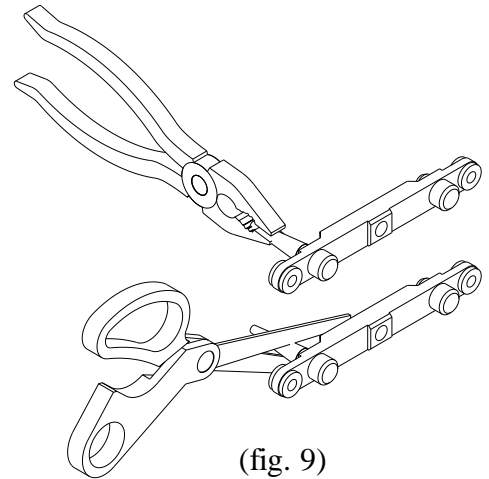

(fig. 9)

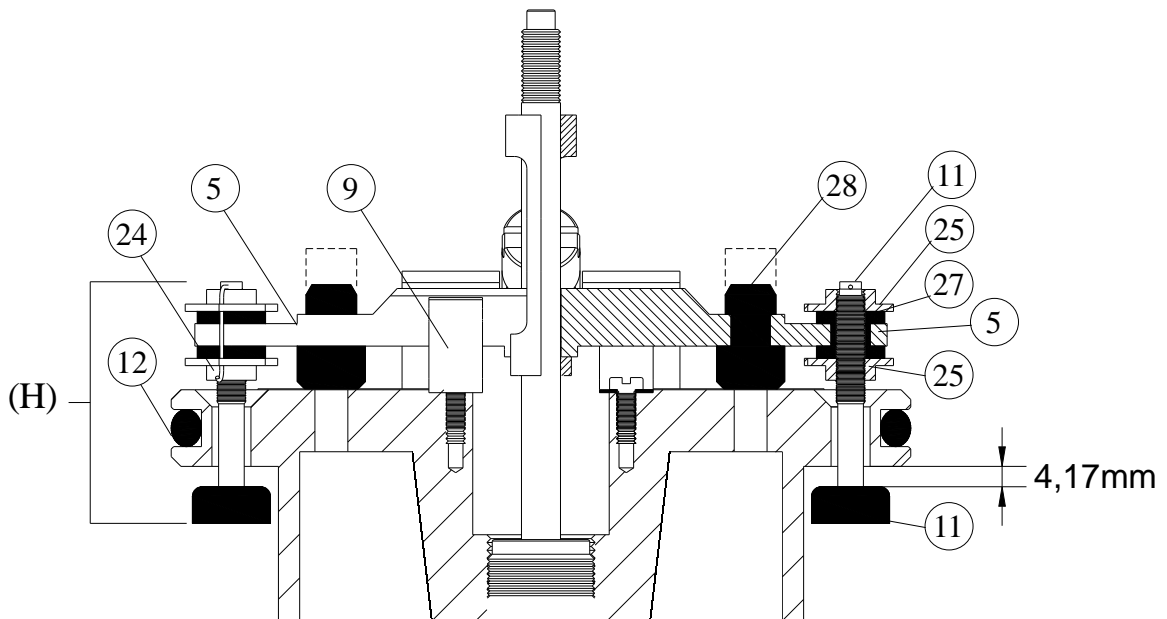

(fig. 8)

TROUBLESHOOTING GUIDE

PROBLEM	POSSIBLE CAUSE	SOLUTION
Pump fails to operate.	<ul style="list-style-type: none"> ■ Restricted line or inadequate air supply. ■ Insufficient air pressure, closed or clogged air valves, etc. ■ Exhausted fluid supply. ■ Obstructed fluid hose, gun or dispensing valve. ■ Clogged spray tip or filters. 	<ul style="list-style-type: none"> ■ Clear, increase air. ■ Open, clean. ■ Refill; purge all air from pump and fluid lines. ■ Clear. ■ Clear or replace.
Pump operates but output low on down stroke.	<ul style="list-style-type: none"> ■ Clogged filters. ■ Throat packings nut too tight or too loose. ■ Exhausted fluid supply. ■ Obstructed fluid hose or gun. ■ Worn spray tip. ■ Held open or worn intake valve. ■ Held open or worn fluid piston or packings. 	<ul style="list-style-type: none"> ■ Clear or replace. ■ Adjust. ■ Refill and prime. ■ Clear. ■ Replace. ■ Clear. ■ Clear or replace.
Erratic or accelerated operating.	<ul style="list-style-type: none"> ■ Exhausted fluid supply. ■ Check valves need adjustment. ■ Held open or worn intake valve. ■ Held open or worn fluid piston or packings. 	<ul style="list-style-type: none"> ■ Refill and prime. ■ Adjust. ■ Clear. ■ Clear or replace.

For trouble free operation is absolutely essential that your sprayer be kept clean and free of residual paint build-up on the internal parts. It must be cleaned and lubricated after each use.

TECHNICAL DATA

PUMPRATIO: 46:1.

RECOMMENDED MAXIMUM AIR SPEED: 60 CYCLES/MIN.

RECOMMENDED AIR PRESSURE: FROM 2 TO 7 BAR.

FLOW AT 60 CYCLES/MIN.: 3,6 LITRES/MIN.

MAXIMUM WORKING PRESSURE: 250 BAR.

STANDARD SPRAY TIPS

ORIFICE SIZE MM / INCHES	FLOW IN LITRES / MIN	FAN WIDTH AT 300 MM.	ORIFICE SIZE MM / INCHES	FLOW IN LITRES / MIN	FAN WIDTH AT 300 MM.
0.23 MM. .009" 9.20 9.40 9.60	0.30	100-150 200-250 300-350	0.53 MM. .021" 21.20 21.40 21.60	1.74	100-150 200-250 300-350
0.28 MM. .011" 11.20 11.40 11.60	0.45	100-150 200-250 300-350	0.58 MM. .023" 23.20 23.40 23.60	2.08	100-150 200-250 300-350
0.33 MM. .013" 13.20 13.40 13.60	0.64	100-150 200-250 300-350	0.63 MM. .025" 25.20 25.40 25.60	2.49	100-150 200-250 300-350
0.38 MM. .015" 15.20 15.40 15.60	0.87	100-150 200-250 300-350	0.68 MM. .027" 27.20 27.40 27.60	2.91	100-150 200-250 300-350
0.43 MM. .017" 17.20 17.40 17.60	1.13	100-150 200-250 300-350	0.74 MM. .029" 29.20 29.40 29.60	3.33	100-150 200-250 300-350
0.48 MM. .019" 19.20 19.40 19.60	1.36	100-150 200-250 300-350	0.79 MM. .031" 31.20 31.40 31.60	3.86	100-150 200-250 300-350

WARRANTY

M.B.P., will any repairs necessary during the first 12 months after purchase of a new unit, with the exceptions shown under 1 and 2 below, and under the conditions shown in item 3.

- 1.- Damage caused by external abuse, customer negligence, or failure to operate the unit in accordance with the instructions supplied with the unit.
- 2.- Normal maintenance items.
- 3.- Within the first 12 months after purchase, M.B.P. will pay 100% of the cost of covered repairs.

In no case will M.B.P. liability extend beyond repair or replacement of the equipment. Such liability is limited to the amount of the original purchase price paid for the unit, minus a reasonable deduction for the time the unit has been in service. It is the responsibility of the purchaser under this warranty to ship or deliver the failed paint sprayer to the authorized service center at the purchaser's expense. Parts or components covered under this warranty may either be repaired or replaced at M.B.P. option.

Equipment not covered by M.B.P. warranty. Accessories or components of equipment sold by M.B.P. that are not manufactured by M.B.P. are subject to the warranty, if any, of their manufacturer. M.B.P. will provide purchaser with reasonable assistance in making such claims.

The Industry Department of The Basque Government, states that all electric and pneumatic airless equipment manufacture by M.B.P. S.L., follows the "CE" standards under the number 83/392/CEE.

DECLARACION DE CONFORMIDAD "CE" "EC" DECLARATION OF CONFORMITY

MODELO / MODEL TEL - 46

Este producto cumple con la siguiente directiva de la Comunidad Europea.

This Product complies with the following European Community Directive.

Directiva 2014/34/EU Atex sobre máquinas. (Ex II 2G c T6 X)

Machinery Directive 2014/34/EU Atex Directive. (Ex II 2G c T6 X)

APROBADO POR /

APPROVED BY

AITOR ORTIZ

FECHA / DATE

MBP, S.L. figura inscrita en el Registro Industrial del País Vasco con el N° 01/8030 y cumple los requisitos para el desarrollo de su actividad comercial.

MBP, S.L. is registered in the Industrial Register of the Basque Country with the N° 01/8030.

