

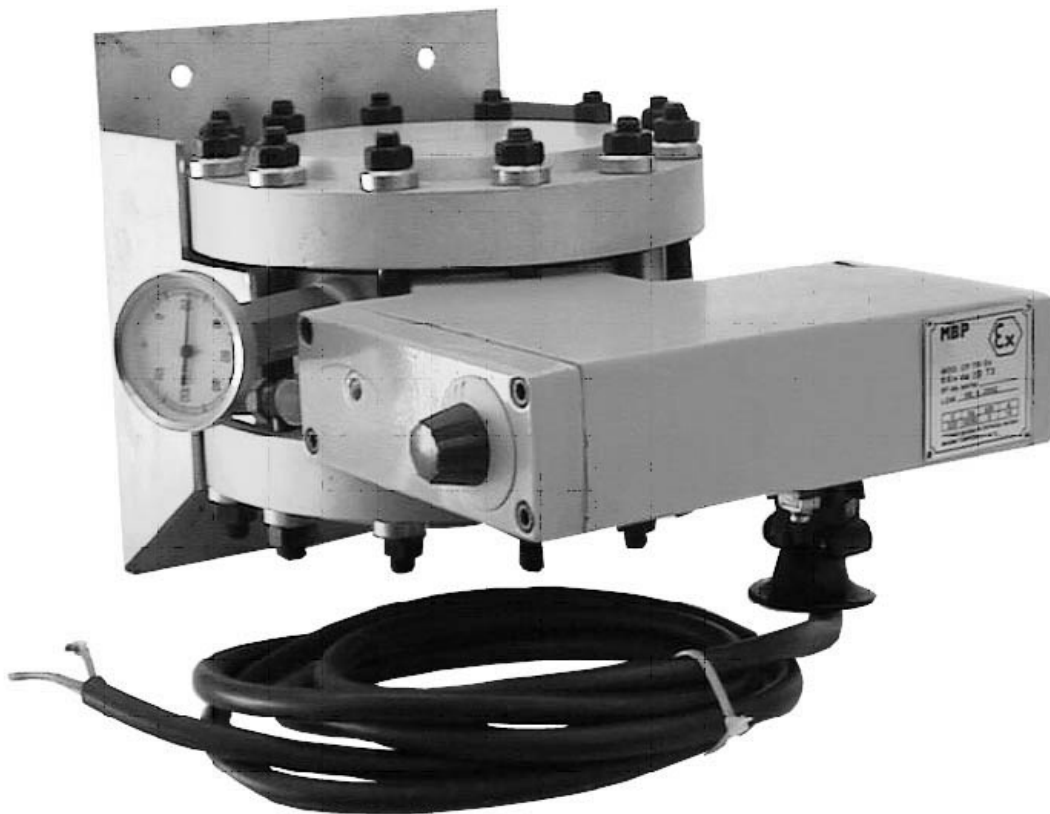

INSTRUCTIONS AND PARTS LIST

This instruction manual contains IMPORTANT WARNINGS AND INSTRUCTION THAT MUST BE READ BEFORE OPERATING THE PUMP

PRODUCT HEATER CP 750 EX



The Heater CP 750 Ex is homologated and conforms with the following Harmonised European Legislation:

EN 50014-1999 "General Rules"
EN 50018-2002 "Antideflagrant Surroundings"
EN 50019-2000 "Increased Security"

WARNING

ATTENTION!!! Read and understand all instructions carefully before operating equipment.

INJECTION HAZARD

This equipment can generate very high fluid pressure. Spray from the gun, leaks or ruptured components can inject fluid through your skin and into your body and cause extremely serious bodily injury.

The spray gun should never be handled carelessly, nor spray directed toward any part of the body. Keep your hands and fingers away from spray gun nozzle.

Be sure equipment safety devices are operating properly before each use.

If any fluid appears to penetrate your skin, get emergency medical care at once. Do not treat as a simple cut. Tell the doctor exactly what fluid was injected.

Never operate the gun with the trigger guard removed. The trigger guard reduces the risk of accidentally triggering the gun if it is dropped or bumped.

PRESSURE RELIEF PROCEDURE

To reduce the risk of serious bodily injury, including injection, burns or injury from moving parts, always follow this procedure whenever you shut off the pump, when checking or servicing any part of the spray system, when installing, cleaning or changing spray tips, and whenever you stop spraying.

1. Engage the gun safety latch.
2. Shut off the air to the pump.
3. Close the bleed-type master air valve.
4. Disengage the gun safety latch.
5. Hold a metal part of the gun firmly to the side of a grounded metal pail, and trigger the gun to relieve pressure.
6. Engage the gun safety latch.
7. Open the fluid filter drain valve having a container ready to catch the drainage.

8. Leave the drain valve open and the director valve in the drain mode until you are ready to spray again.

9. Shut off the power to the heater. Allow the fluid and the heater to cool before touching to reduce the risk of burning yourself.

EQUIPMENT MINUSE HAZARD

Heat causes fluid to expand. If fluid in the heated portion of your system is trapped with no where to expand, it can cause a system rupture, resulting in serious bodily injury and property damage. To reduce the risk of overheating the fluid, be sure your system has an adequate way to handle heat expansion: use flexible hoses between the heater and gun, use the heater in a circulating system, or provide an over-temperature safety relief valve, or provide adequate heat dissipation. Never install any shutoff device between the heater and gun. If you are using a fluid regulator before the gun, never use it as a shutoff device.

This heater has a 180 bar maximum working pressure. Do not exceed this pressure of any component or accessory used in that system.

Be sure that all accessories you add to the system are properly rated to withstand the maximum air and fluid working pressure and temperatures of the system.

FIRE OR EXPLOSION HAZARD

Static electricity is created by the high velocity flow of fluid through the pump and hose. If every part of the spray equipment is not properly grounded, sparking may occur, and the system may become hazardous. Sparking may also occur when plugging in or unplugging a power supply cord. Sparks can ignite fumes from solvents and the fluid being sprayed, dust particles and other flammable substances, whether you are spraying indoors or outdoors, and can cause a fire or explosion and serious bodily injury. Do not plug in or unplug any power supply cords in the spray area when there is any chance of igniting fumes still in the air.

If you experience any static sparking or even a slight shock while using this equipment, stop spraying immediately. Check the entire system for proper grounding. Do not use the system again until the problem has been identified and corrected.

GROUNDING

To reduce the risk of static sparking, ground the pump and all other spray equipment used or located in the spray area. Be sure to ground all of this spray equipment:

1. Pump: use a ground wire and clamp.
2. Air hoses: use only grounded air hoses.
3. Fluid hoses: use only grounded fluid hoses.
4. Heater: by wiring to a properly grounded power supply through the electrical connections.
5. Air compressor: follow manufacturer's recommendations.
6. Spray gun: grounding is obtained through connection to a properly grounded fluid hose and pump.
7. Object being sprayed: according to your local code.
8. Solvent pails used when flushing: use only metal pails, which are conductive, placed on a grounded surface.
9. To maintain grounding continuity when flushing or relieving pressure, always hold a metal part of the gun firmly to the side of a grounded metal pail, then trigger the gun.

All electrical wiring should be performed only by trained and qualified personnel in compliance with all local codes.

Never operate with covers removed. Conductors used for the supply connection shall be suitable for at least 250°C.

WIRING

All wire nut used for heater connections must be rated at 250°C or higher. Never use wire nuts less than 250°C, they can not withstand the heat generated.

Be sure your voltage supply agrees with the heater voltage. The 220 volt heater draws 16 amps.

The kind of wire used must be of 2,5 mm² and it have to tolerate 250°C (for example the wire IESIL CAE/NCAE 5018).

FLUSHING

This heater was factory tested with a lightweight oil. Use low pressure and a compatible solvent to flush the system. While

the system is pressurised, check it carefully for leaks at all fluid connections. Pump out the solvent, relieve the system pressure and tighten any leaking connections. Prime the system and check to be sure that all leaks have stopped.

SETTING HEATER CONTROLS

Stop the pump, set the control knob at 4 or 5 and let the heater warm up for about 10 minutes.

Start the pump and circulate the fluid at a low speed during warm up.

For adjusting for spraying, start the pump and check the fluid flow through the gun. Readjust the control knob setting, if necessary, to obtain the proper temperature for spraying.

Use the lowest temperature setting needed, for maximum heater life. Operating the heater at its highest setting for long periods of time decreases the heater life. Higher than necessary temperature also cause the fluid to dry out, resulting in a poor finish and clogging the heater.

MAINTENANCE

Drain and clean the fluid filter frequently. Always relieve system pressure first, and cool the fluid, if possible. If not possible wear protective eyewear and gloves to protect yourself from possible burns.

Flush the heater often enough to prevent a build-up of dried sediment in it.

Before flushing, always shut off the main power to the heater. Circulate the fluid through the system for at least 10 minutes to cool the fluid and heater.

Clogged fluid passages can be very difficult to clean. They also reduce heating efficiency, flow rate and pressure. To prevent clogged passages, do not overheat or dry out the fluid, and flush frequently, including whenever the system or heater is not in use.

If the system runs dry, refill it immediately before fluid can dry in it. Or flush the system thoroughly if you are not going to use it immediately.

When shutting down the system, turn the control knob to set point 1 and circulate the fluid for at least 10 minutes before shutting off the pump. This allows unheated fluid to gradually cool the heater and heated fluid.

PARTS DRAWING

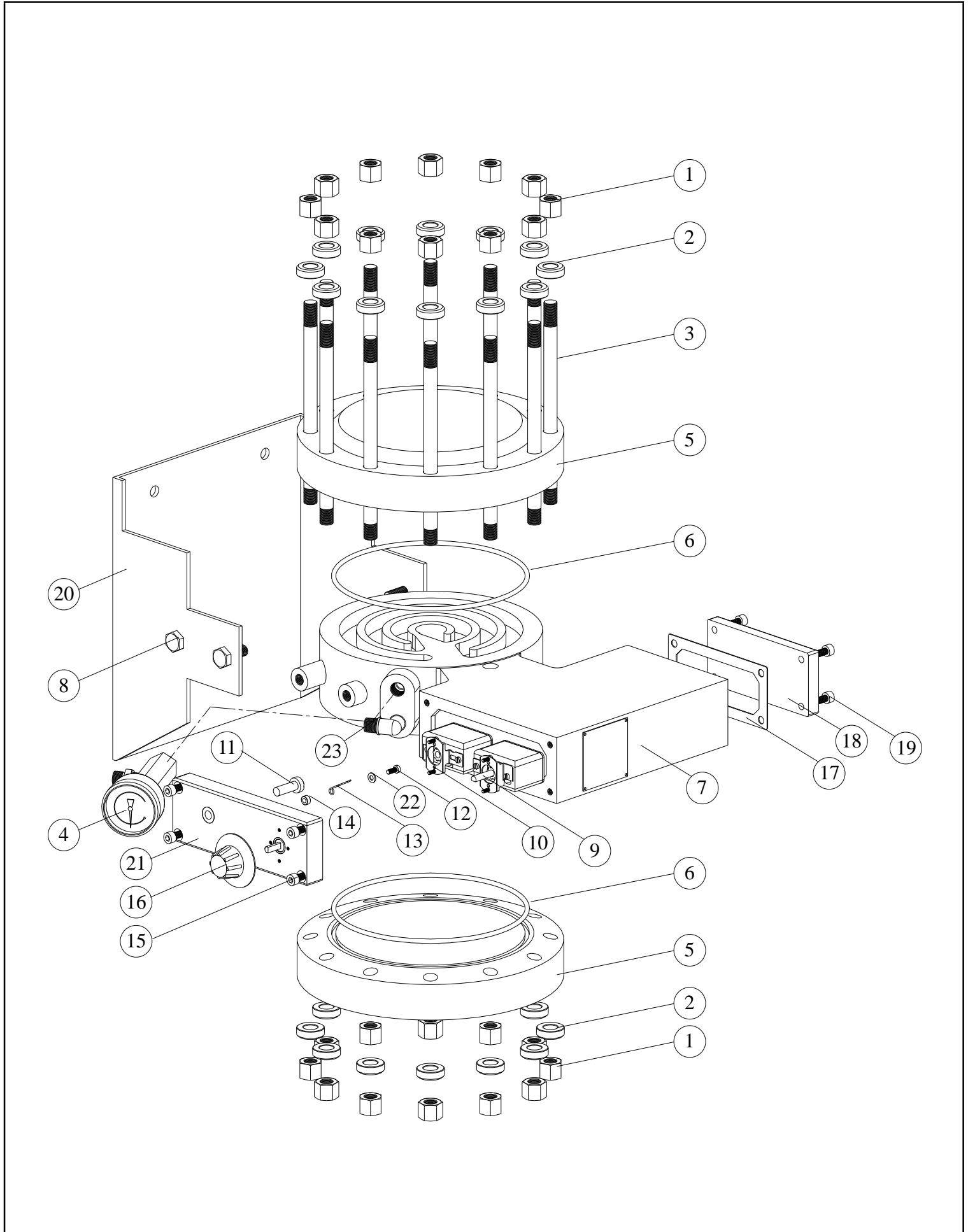

PARTS LIST

| N° | DESCRIPTION | REF |
|-----------|-----------------------|------------|
| 1 | NUT | 101.000.11 |
| 2 | WASHER | 101.000.07 |
| 3 | TIE | 101.000.06 |
| 4 | THERMOMETER | 101.300.00 |
| 5 | COVER | 101.000.05 |
| 6 | JOINT | CJT.020 |
| 7 | BODY | 101.100.00 |
| 8 | SCREW | CTA.005 |
| 9 | REGULATION THERMOSTAT | 101.200.01 |
| 10 | SAFETY THERMOSTAT | 101.200.06 |
| 11 | REASSEMBLE KNOB | 101.200.03 |
| 12 | SCREW | CTH.006 |
| 13 | SPRING | 101.200.04 |
| 14 | SPRING SEAT | 101.200.05 |
| 15 | SCREW | CTB.001 |
| 16 | THERMOSTAT CONTROL | 101.000.10 |
| 17 | JOINT | 101.000.02 |
| 18 | COVER | 101.000.01 |
| 19 | SCREW | CTB.001 |
| 20 | SUPPORT | 101.000.08 |
| 21 | COVER | 101.210.00 |
| 22 | WASHER | CAR.002 |
| 23 | RACORD | CNA.063 |

TYPICAL INSTALLATION

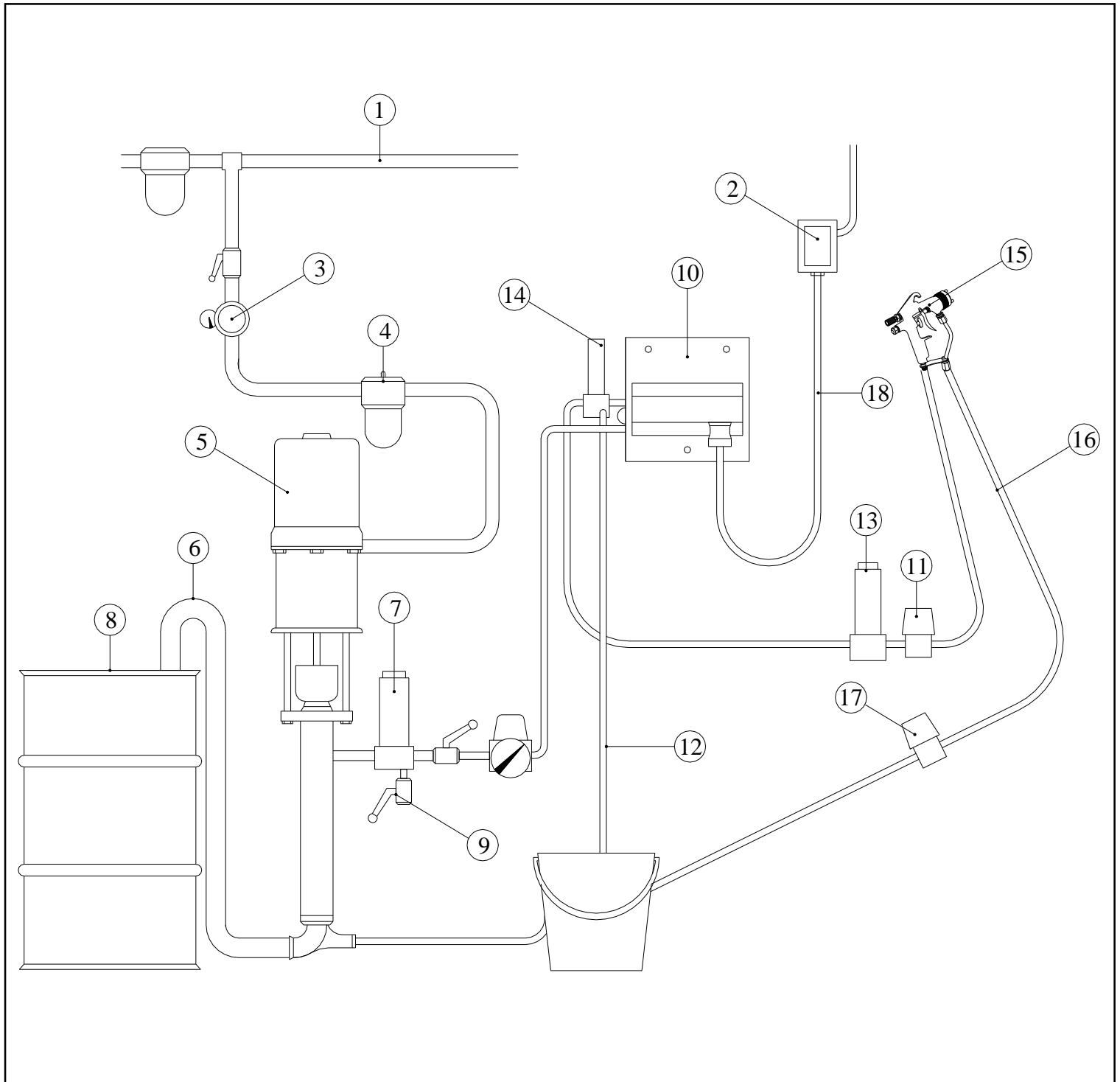

| N° | Description |
|----|---------------|
| 1 | Air line |
| 2 | Switch |
| 3 | Air regulator |
| 4 | Lubricator |
| 5 | Pump |
| 6 | Suction pipe |

| N° | Description |
|----|--------------|
| 7 | H.P. Filter |
| 8 | Product pail |
| 9 | Drain valve |
| 10 | Heater |
| 11 | Regulator |
| 12 | Drain |

| Num | Description |
|-----|----------------------|
| 13 | H.P. Filter |
| 14 | Accumulator / relief |
| 15 | Gun |
| 16 | Hose |
| 17 | Back regulator |
| 18 | Wire |

Troubleshooting guide

| PROBLEM | CAUSE | SOLUTION |
|--|---|---|
| Heater will not heat. | <ul style="list-style-type: none"> - No current. - Burned out heating element. - The safety thermostat has actuated. | <ul style="list-style-type: none"> - Check circuit, fuses. - Replace the part n°7. - Rearm pulsatin part n°11. |
| Temperature too low. | <ul style="list-style-type: none"> - Fluid requires more warm up time. - Wrong temperature setting. - Flow rate too high. - Clogged fluid passages. | <ul style="list-style-type: none"> - Increase warm up time. - Adjust the knob. - Reduce the flow rate. - Clean. |
| Temperature too high. | <ul style="list-style-type: none"> - Wrong temperature setting. - Faulty thermostat n°9. | <ul style="list-style-type: none"> - Adjust the knob. - Replace. |
| Too much pressure drop / Fluid will not flow. | <ul style="list-style-type: none"> - Flow rate too high. - Clogged fluid passages. | <ul style="list-style-type: none"> - Reduce the flow rate. - Clean - Remove the covers n°5 and clean inside. |

TECHNICAL SPECIFICATIONS.

- Max. working pressure: 180 bar
- Voltage: 220 V - 16 Amp.
- Power: 3KW.
- Temperature range: 20 - 80°C.
- Weight: 34 Kgs.

WARRANTY

M.B.P., will any repairs necessary during the first 12 months after purchase of a new unit, with the exceptions shown under 1 and 2 below, and under the conditions shown in item 3.

- 1.- Damage caused by external abuse, customer negligence, or failure to operate the unit in accordance with the instructions supplied with the unit.
- 2.- Normal maintenance items.
- 3.- Within the first 12 months after purchase, M.B.P. will pay 100% of the cost of covered repairs.

In no case will M.B.P. liability extend beyond repair or replacement of the equipment. Such liability is limited to the amount of the original purchase price paid for the unit, minus a reasonable deduction for the time the unit has been in service. It is the responsibility of the purchaser under this warranty to ship or deliver the failed paint sprayer to the authorized service center at the purchaser's expense. Parts or components covered under this warranty may either be repaired or replaced at M.B.P. option.

Equipment not covered by M.B.P. warranty. Accessories or components of equipment sold by M.B.P. that are not manufactured by M.B.P. are subject to the warranty, if any, of their manufacturer. M.B.P. will provide purchaser with reasonable assistance in making such claims.

The Industry Department of The Basque Government, states that all electric and pneumatic airless equipment manufacture by M.B.P. S.L., follows the "CE" standards under the number 83/392/CEE.

DECLARACION DE CONFORMIDAD "CE" "EC" DECLARATION OF CONFORMITY

MODELO / MODEL CP 750 EX

Este producto cumple con la siguiente directiva de la Comunidad Europea.

This Product complies with the following European Community Directive.

Directiva 2014/34/EU Atex sobre máquinas. (Ex II 2G c T6 X)

Machinery Directive 2014/34/EU Atex Directive. (Ex II 2G c T6 X)

APROBADO POR /

APPROVED BY

AITOR ORTIZ

FECHA / DATE

MBP, S.L. figura inscrita en el Registro Industrial del País Vasco con el N° 01/8030 y cumple los requisitos para el desarrollo de su actividad comercial.

MBP, S.L. is registered in the Industrial Register of the Basque Country with the N° 01/8030.

